

HIGH-PERFORMANCE LAMBDA SPECTROMETERS

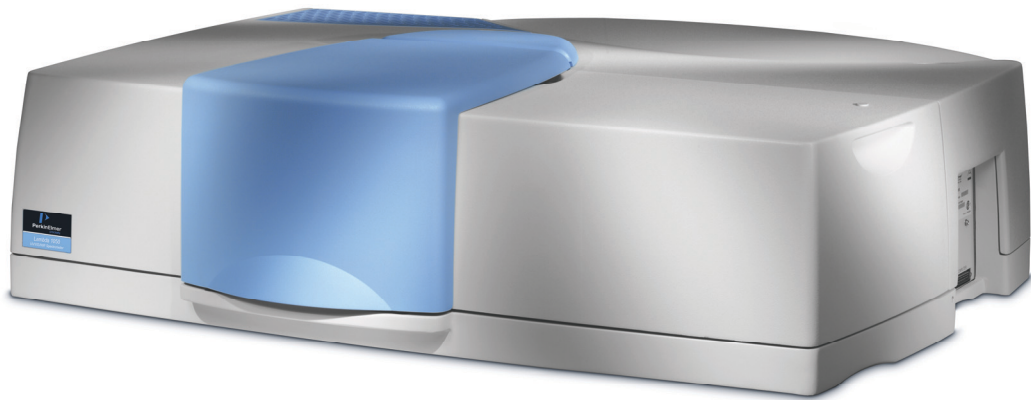

Hardware Guide

Release History

Part Number	Release	Publication Date
L6050008	A	December 2007

Any comments about the documentation for this product should be addressed to:

User Assistance
PerkinElmer Ltd
Chalfont Road
Seer Green
Beaconsfield
BUCKS
HP9 2FX
United Kingdom

Or emailed to: info@perkinelmer.com

Notices

The information contained in this document is subject to change without notice.

Except as specifically set forth in its terms and conditions of sale, PerkinElmer makes no warranty of any kind with regard to this document, including, but not limited to, the implied warranties of merchantability and fitness for a particular purpose.

PerkinElmer shall not be liable for errors contained herein for incidental consequential damages in connection with furnishing, performance or use of this material.

Copyright Information

This document contains proprietary information that is protected by copyright.

All rights are reserved. No part of this publication may be reproduced in any form whatsoever or translated into any language without the prior, written permission of PerkinElmer, Inc.

Copyright © 2007 PerkinElmer, Inc.

Trademarks

Registered names, trademarks, etc. used in this document, even when not specifically marked as such, are protected by law.

PerkinElmer is a registered trademark of PerkinElmer, Inc.

Table of Contents

Introduction	5
Overview	6
Conventions Used in this Manual.....	8
Notes, Cautions and Warnings	8
Safety Practices	11
Overview	12
Precautions.....	13
General Operating Conditions	14
Environmental Conditions.....	15
Other Environmental Conditions	15
Electrical Safety.....	17
Electrical Safety Issues	18
EMC Compliance.....	19
Warning Labels	20
Fuses	22
Moving the Instrument.....	24
System Description	25
Overview	26
Optical System	27
Lambda 650/750/850/950 Spectrometer	27
Lambda 1050 Spectrometer	29
Installing your Lambda Spectrometer	33
Overview	34
Site Requirements.....	34
Unpacking	35
Connecting to the Line Power Supply	37
Connecting the System Components	38
Connecting to the PC.....	38
Setting up the Instrument in the Software	39
Calibrating the Instrument	43
Installing Accessories.....	46
Removing the Parts of the Sample Compartment.....	46
Removing the Detector Unit.....	48
Accessory Connector Panel	49
Overview of Accessory Installation.....	51
Pin Configuration	52
Using the Spectrometer	53
Startup Procedure	54
The Single-Cell Holder.....	55
Description	55
Installing the Single-Cell Holder.....	55
Aligning the Single-Cell Holder	56
Fine Alignment	58
Minimum Volume Applications.....	58
Purging the Instrument.....	60
Maintenance	63
Overview	64
Daily Checks	65
Cleaning the Instrument Covers	65
Cleaning the Sample Compartment.....	65
Sample Compartment Windows.....	66
Use and Care of Cells	67

Replacing a Lamp	68
Halogen Lamp Replacement.....	69
Deuterium Lamp Replacement.....	70
Replacement Parts.....	73
Appendices.....	75
Appendix 1: WEEE Instructions for PerkinElmer Products	76
Appendix 2: Guaranteed Performance Specifications	77
Guaranteed Specifications of the UV/Vis Lambda Spectrometers.....	77
Guaranteed Specifications of the UV/Vis/NIR Lambda Spectrometers..	79

Introduction

Overview

This hardware guide describes the operating procedures for the Lambda 650, 750, 850, 950 and 1050 spectrometers, plus those maintenance routines that do not necessarily require a PerkinElmer Service Engineer.

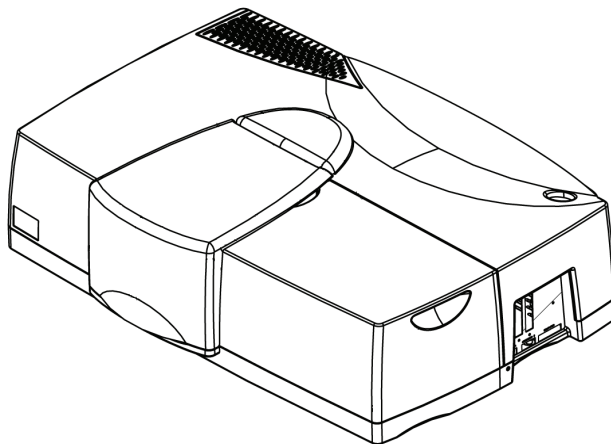

Figure 1 High-performance Lambda spectrometer

There are separate manuals for the sphere and universal reflectance accessories which can be found on the *High-Performance Lambda Spectrometers Manuals CD* (L6050009).

This manual is divided into following chapters:

Introduction

This chapter contains a brief introduction to the instrument, and the conventions and warnings used in the manual.

Safety Practices

Important safety information is provided in this chapter. This is the same information that is included in the *High-Performance Lambda Spectrometers Getting Started Guide* (L6050007) that shipped with your instrument.

System Description

This chapter contains information on the components of the instrument and how it works.

Installing your Lambda Spectrometer

Information on installing your high-performance Lambda spectrometer is provided, although the first-time installation will be performed by a PerkinElmer Service Engineer. This is the same information as given in the *High-Performance Lambda Spectrometers Getting Started Guide* (L6050007) that shipped with your instrument.

Using the Spectrometer

The startup procedure and general instructions for using the instrument are provided.

Maintenance

Maintenance and cleaning procedures for the various components of your instrument are provided.

Appendices

Appendix 1 covers Waste Electrical and Electronic Equipment (WEEE) instructions for the disposal of PerkinElmer Products.

Appendix 2 provides the minimum performance specifications of the Lambda spectrometers.

Conventions Used in this Manual

Normal text is used to provide information and instructions.

Bold text refers to text that is displayed on the screen.

UPPERCASE text, for example ENTER or ALT, refers to keys on the PC keyboard. The symbol '+' is used to show that you have to press two keys at the same time, for example, ALT+F.

All eight digit numbers are PerkinElmer part numbers unless stated otherwise.

Unless stated otherwise, high-performance Lambda spectrometer refers to the Lambda 650, 750, 850, 950, 1050 WB or 1050 NB spectrometer, as applicable.

Notes, Cautions and Warnings

Three terms, in the following standard formats, are also used to highlight special circumstances and warnings.

<p>NOTE: A note indicates additional, significant information that is provided with some procedures.</p>

CAUTION

We use the term **CAUTION** to inform you about situations that could result in **serious damage to the instrument** or other equipment. Details about these circumstances are in a box like this one.

D**Caution (Achtung)**

Bedeutet, daß die genannte Anleitung genau befolgt werden muß, um einen **Geräteschaden** zu vermeiden.

DK**Caution (Bemærk)**

Dette betyder, at den nævnte vejledning skal overholdes nøje for at undgå en **beskadigelse af apparatet**.

E**Caution (Advertencia)**

Utilizamos el término **CAUTION (ADVERTENCIA)** para advertir sobre situaciones que pueden provocar **averías graves en este equipo** o en otros. En recuadros éste se proporciona información sobre este tipo de circunstancias.

F**Caution (Attention)**

Nous utilisons le terme **CAUTION (ATTENTION)** pour signaler les situations susceptibles de provoquer de **graves détériorations de l'instrument** ou d'autre matériel. Les détails sur ces circonstances figurent dans un encadré semblable à celui-ci.

I**Caution (Attenzione)**

Con il termine **CAUTION (ATTENZIONE)** vengono segnalate situazioni che potrebbero arrecare **gravi danni allo strumento** o ad altra apparecchiatura. Troverete informazioni su tali circostanze in un riquadro come questo.

NL**Caution (Opgelet)**

Betekent dat de genoemde handleiding nauwkeurig moet worden opgevolgd, om **beschadiging van het instrument** te voorkomen.

P**Caution (Atenção)**

Significa que a instrução referida tem de ser respeitada para evitar a **danificação do aparelho**.



WARNING

We use the term **WARNING** to inform you about situations that could result in **personal injury** to yourself or other persons. Details about these circumstances are in a box like this one.

D

Warning (Warnung)

Bedeutet, daß es bei Nichtbeachten der genannten Anweisung zu einer **Verletzung** des Benutzers kommen kann.

DK

Warning (Advarsel)

Betyder, at brugeren kan blive **kvæstet**, hvis anvisningen ikke overholdes.

E

Warning (Peligro)

Utilizamos el término **WARNING (PELIGRO)** para informarle sobre situaciones que pueden provocar **daños personales** a usted o a otras personas. En los recuadros como éste se proporciona información sobre este tipo de circunstancias.

F

Warning (Danger)

Nous utilisons la formule **WARNING (DANGER)** pour avertir des situations pouvant occasionner des **dommages corporels** à l'utilisateur ou à d'autres personnes. Les détails sur ces circonstances sont données dans un encadré semblable à celui-ci.

I

Warning (Pericolo)

Con il termine **WARNING (PERICOLO)** vengono segnalate situazioni che potrebbero provocare **incidenti alle persone**. Troverete informazioni su tali circostanze in un riquadro come questo.

NL

Warning (Waarschuwing)

Betekent dat, wanneer de genoemde aanwijzing niet in acht wordt genomen, dit kan leiden tot **verwondingen** van de gebruiker.

P

Warning (Aviso)

Significa que a não observância da instrução referida poderá causar um **ferimento** ao usuário.

Safety Practices

Overview

This chapter describes the general safety practices and precautions that must be observed when operating your high-performance Lambda spectrometer.

This advice is intended to supplement, not supersede, the normal safety codes in the user's country. It is also a supplement to the PerkinElmer standard Safety and Health Policy. The information provided does not cover every safety procedure that should be practiced. Ultimately, maintenance of a safe laboratory environment is the responsibility of the analyst and the analyst's organization.

Please consult all manuals and CDs supplied with your high-performance Lambda spectrometer and accessories before you start working with the instrument. Carefully read the safety information in this chapter and in the other manuals supplied. When setting up the instrument, or performing analyses or maintenance procedures, strictly follow the instructions provided.

Precautions



WARNING

Be sure that all instrument operators read and understand the precautions listed below. It is advisable to post a copy of the precautions near or on the instrument itself.

The following precautions must be observed when using your high-performance Lambda spectrometer:

- Connect the instrument to a correctly installed line power outlet that has a protective conductor (earth/ground).
- Do not attempt to make internal adjustments or replacements except as directed in this handbook.
- Do not operate the instrument with any covers or parts removed.
- Servicing should only be carried out by a PerkinElmer Service Engineer or a similarly authorized and trained person.
- Disconnect the instrument from all voltage sources before opening it for any adjustment, replacement, maintenance, or repair. If, afterwards, the opened instrument must be operated for further adjustment, maintenance, or repair, this must only be done by a skilled person who is aware of the hazard involved.
- Use fuses with the required current rating only and of the specified type only for replacement.
- Do not use makeshift fuses or short-circuit the fuse holders.



WARNING

If the equipment is used in a manner not specified herein, then the protection provided by the equipment may be impaired.

General Operating Conditions

Only use your high-performance Lambda spectrometer indoors and under the following conditions:

Temperature 15 °C to 35 °C

Relative Humidity 80% maximum (non-condensing)

If possible, avoid any adjustment, maintenance or repair of the opened, operating instrument. If any adjustment, maintenance or repair of the opened instrument is necessary, this must be done by a skilled person who is aware of the hazard involved.

Whenever it is likely that your high-performance Lambda spectrometer is unsafe, make it inoperative. The high-performance Lambda spectrometer may be unsafe if it:

- shows visible damage;
- fails to perform the intended measurement;
- has been subjected to prolonged storage in unfavorable conditions;
- has been subjected to severe transport stresses.

Environmental Conditions

The instrument has been designed to be safe under the following conditions:

- Indoor use;
- Altitude up to 2000 m;
- Ambient temperatures of 5 °C to 40 °C;
- A maximum ambient relative humidity of 80% for temperatures up to 31 °C, decreasing linearly to 50% relative humidity at 40 °C;
- Mains fluctuations not exceeding $\pm 10\%$ of the nominal voltage.



WARNING

This instrument is not designed for operation in an explosive atmosphere.

Other Environmental Conditions

Chemicals

Use, store, and dispose of chemicals that you require for your analyses in accordance with the manufacturer's recommendations and local safety regulations.



WARNING

Hazardous Chemicals

Some chemicals used with this instrument may be hazardous or may become hazardous after completion of an analysis.

The responsible body (for example, the Laboratory Manager) must take the necessary precautions to ensure that the surrounding workplace and instrument operators are not exposed to hazardous levels of toxic substances (chemical or biological) as defined in the applicable Material Safety Data Sheets (MSDS) or OSHA, ACGIH, or COSHH documents.

Venting for fumes and disposal of waste must be in accordance with all national, state and local health and safety regulations and laws.

OSHA: Occupational Safety and Health Administration (U.S.A.)

ACGIH: American Conference of Governmental Industrial Hygienists (U.S.A)

COSHH: Control of Substances Hazardous to Health (U.K.)

Toxic Fumes

If you are working with volatile solvents or toxic substances, then you must provide an efficient laboratory ventilation system to remove vapors that may be produced when you are performing analyses.

Waste Disposal

Waste containers may contain corrosive or organic solutions and small amounts of the substances that were analyzed. If these materials are toxic, you may have to treat the collected effluent as hazardous waste. Refer to your local safety regulations for proper disposal procedures.

Deuterium lamps and other spectral lamps are maintained under reduced pressure. When you dispose of lamps that are defective or otherwise unusable, handle them correctly to minimize the implosion risk.

UV Radiation

You should be aware of the health hazards presented by ultraviolet radiation.

- When the deuterium (UV) lamp is illuminated, do not open the spectrophotometer covers unless specifically instructed to do so in the manual.
- Always wear UV-absorbing eye protection when the deuterium lamp is exposed.
- Never look directly into the deuterium lamp.

Compressed Gases

Handle cylinders of compressed gas with care, in accordance with local regulations.

We recommend that gas cylinders be located outside the laboratory and the gases led to the laboratory through approved gas supply lines.

Use only approved tubing, connectors, and regulators for gas supply lines.

Electrical Safety

The high-performance Lambda spectrometer has been designed and tested in accordance with PerkinElmer specifications and in accordance with the safety requirements of the International Electrotechnical Commission (IEC). The high-performance Lambda spectrometer conforms to IEC 61010-1 (Safety Requirements for electrical equipment for measurement, control and laboratory use) as it applies to IEC Class 1 (earthed) appliances and therefore meets the requirements of EC directive 2006/95/EC.

This instrument meets the Canadian Standards Association (CSA) Standard CAN/CSA-C22.2 No. 61010-1-04: *Laboratory Equipment*.

The instrument has been designed to protect the operator from potential electrical hazards. This section describes some recommended electrical safety practices.



Electrical Hazard

Any interruption of the protective conductor inside or outside the instrument or disconnection of the protective conductor (earth/ground) terminal is likely to make the instrument dangerous.

Intentional interruption is prohibited.

Lethal Voltages are Present in the Instrument

- *Even with the power switch OFF, line power voltages can still be present within the instrument.*
- *When the instrument is connected to line power, terminals may be live, and opening covers or removing parts (except those to which access can be gained without the use of a tool) is likely to expose live parts.*
- *Capacitors inside the instrument may still be charged even if the instrument has been disconnected from all voltage sources.*

Electrical Safety Issues

To ensure satisfactory and safe operation of the instrument, it is essential that the green/yellow lead of the line power cord is connected to true electrical earth (ground).

If any part of the instrument is not installed by a PerkinElmer Service Engineer, make sure that the line power plug is wired correctly.

Terminal	Cord Lead Colors	
	International	USA
Live	Brown	Black
Neutral	Blue	White
Protective Conductor (earth/ground)	Green/Yellow	Green

NOTE: The instrument must always be positioned so that it can be easily disconnected from the power supply.

EMC Compliance

EMC directive

This product has been designed and tested to meet the requirements of the EMC directive 2004/108/EC.

FCC rules and regulations

This product is classified as a digital device used exclusively as industrial, commercial, or medical test equipment. It is exempt from the technical standards specified in Part 15 of the FCC Rules and Regulations based on Section 15.103(c).

Warning Labels

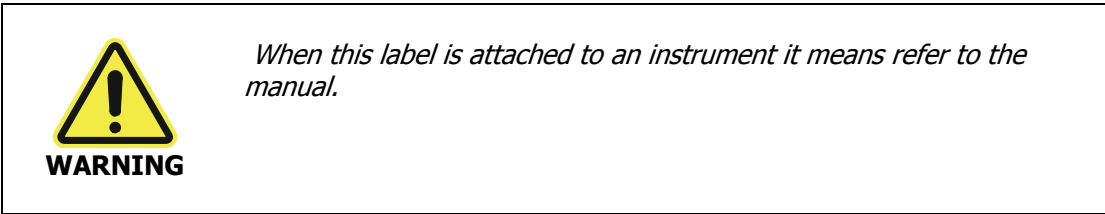

The following electrical warnings are shown on the rear of the instrument, as identified in Figure 2:

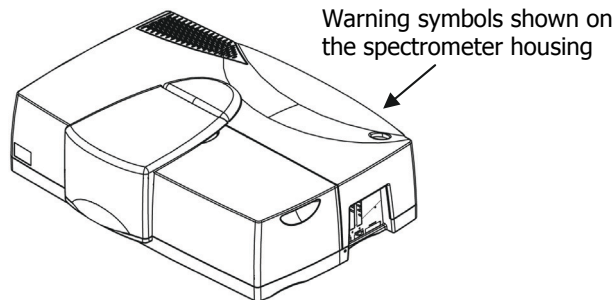
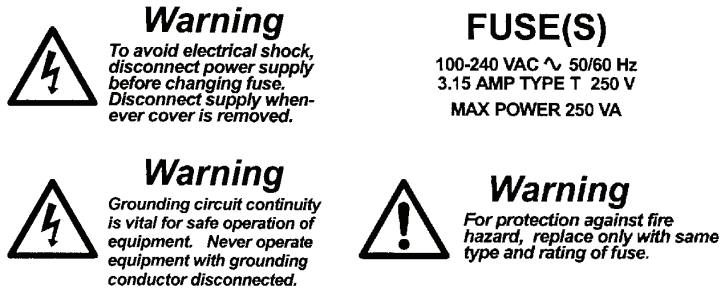

Figure 2 Warning labels on the High-performance Lambda spectrometer

The following warnings are shown on the inside of the lamp compartment, as identified in Figure 3:

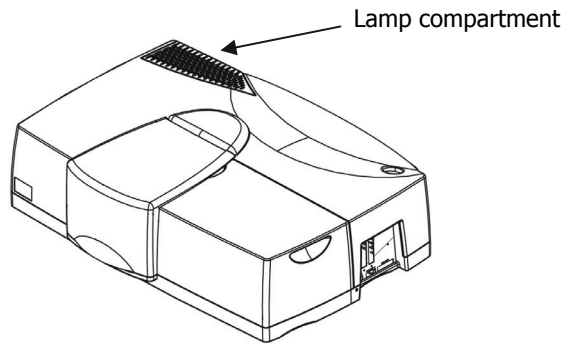

Figure 3 Position of the lamp compartment

Fuses



Electrical Hazard

To prevent potential injury to yourself and damage to the instrument, switch OFF all instruments in the system and disconnect them from the line power supply before you alter, or make any new, electrical connections.

The fuses are located in a fuse holder at the rear of the instrument, as shown in Figure 4.

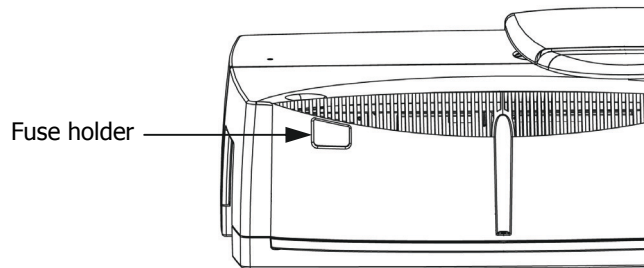

Figure 4 Rear view of the fuse holder

To change the fuses:

1. Switch off the instrument and remove the line power cord from the electrical supply.
2. Squeeze in and lever out the two lugs at each side of the fuse holder one at a time using a flat-headed screwdriver.
3. Gently pull out the fuse holder, as shown in Figure 5.

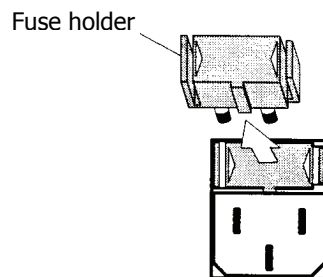

Figure 5 Removing the fuse holder

4. Replace the fuses with new ones of the same type and rating (3.15 A time delay).

NOTE: The module has two fuses and you should always replace both at the same time, even if only one blew, as the other may have been weakened.

5. Replace the fuse holder by aligning the lug at the bottom of the fuse holder with the slot in the socket and then pushing the holder into place.

You can hear a click as each lug snaps into place.

NOTE: If you use the correct fuses but the instrument still does not work correctly, or the fuses blow repeatedly, contact your PerkinElmer Service Engineer.

Moving the Instrument



WARNING

The instrument weighs about 77 kg. Four people are needed to lift the instrument.

CAUTION

If you must move the instrument any great distance, especially if the instrument may be subject to vibrations or jolts, then contact your local PerkinElmer service representative for guidance or advice.

If you are only moving the instrument within the laboratory or to a nearby laboratory then four people should lift the instrument using the handholds, as shown in Figure 6.

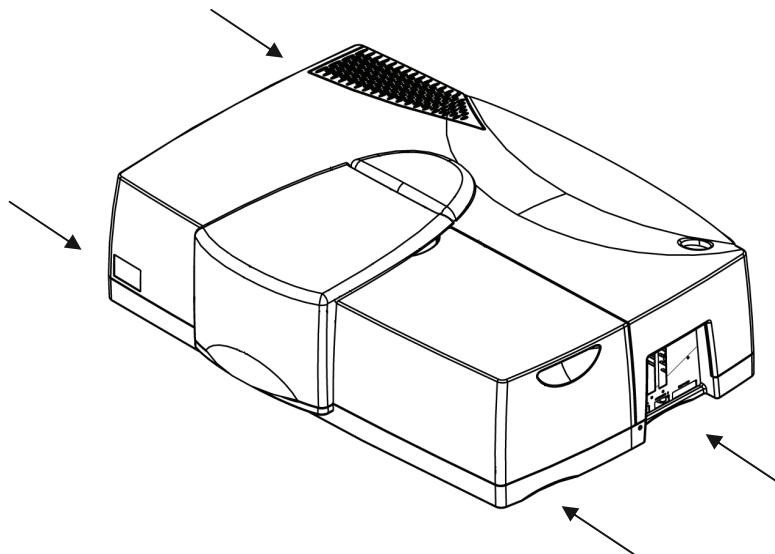

Figure 6 Position of handholds for lifting the instrument

System Description

Overview

The Lambda 650, 750, 850, 950 and 1050 spectrometers are versatile instruments operating in the ultraviolet and visible (UV/Vis) spectral ranges. Additionally, the Lambda 750, 950, and 1050 spectrometers operate in the near-infrared (NIR) region. The spectrometer features a double-beam, double-monochromator, ratio-recording optical system.

These instruments are usable in a wide range of applications, as indicated by their performance specifications. For details of the minimum performance specifications for the high-performance spectrometers, see *Appendix 2: Guaranteed Performance Specifications* on page 77.

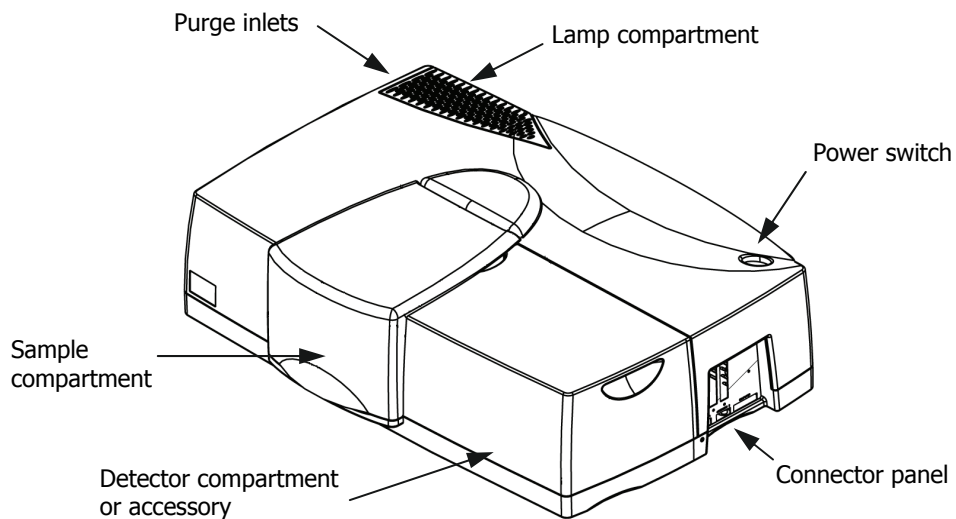

Figure 7 Main features of the high-performance Lambda spectrometer

Optical System

The high-performance Lambda spectrometer features an all-reflecting, double-monochromator optical system. The optical components are coated with silica for durability. Holographic gratings are used in each monochromator for the UV/Vis range and the NIR range.

Lambda 650/750/850/950 Spectrometer

The optical system of the Lambda 650/750/850/950 spectrometer is shown in Figure 8.

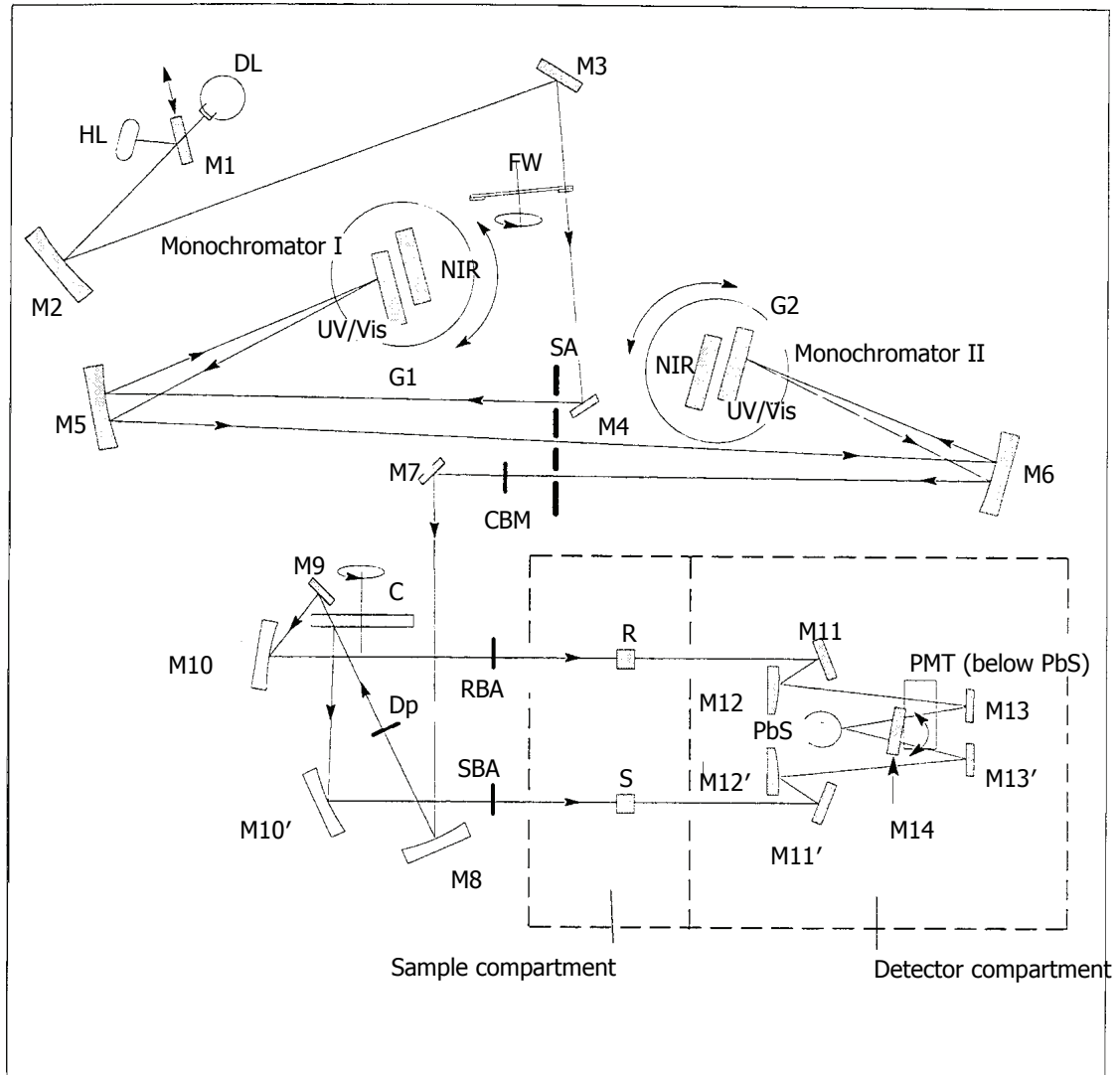

Figure 8 Schematic of the Lambda 650/750/850/950 optical system

Two radiation sources, a deuterium lamp (DL) and a halogen lamp (HL), cover the working wavelength range of the spectrometer.

For operation in the near-infrared (NIR) and visible (Vis) ranges, source mirror M1 reflects the radiation from the halogen lamp onto mirror M2. At the same time it blocks the radiation from the deuterium lamp.

For operation in the ultraviolet (UV) range, mirror M1 is raised to permit radiation from the deuterium lamp to strike source mirror M2. Source change is automatic during monochromator slewing.

Radiation from the respective source lamp is reflected from mirror M2 via mirror M3 through an optical filter on the filter-wheel assembly (FW) to mirror M4.

The filter wheel is driven by a stepping motor to be in synchronization with the monochromators. Depending on the wavelength being produced, the appropriate optical filter is located in the beam path to prefilter the radiation before it enters the monochromator. Filter change is automatic during monochromator slewing.

From mirror M4, the radiation is reflected through the entrance slit of Monochromator I. All slits are located on the slit assembly (SA). The radiation is collimated at mirror M5 and reflected to the grating table G1. Depending on the current wavelength range, the collimated radiation beam strikes either the UV/Vis grating or the NIR grating.

NOTE: The NIR grating is not available in the Lambda 650 or 850 spectrometers.

The radiation is dispersed at the grating to produce a spectrum. The rotational position of the grating effectively selects a segment of the spectrum, reflecting this segment to mirror M5 and then through the exit slit. The exit slit restricts the spectrum segment to a near-monochromatic radiation beam. Grating change is automatic during monochromator slewing.

The exit slit of Monochromator I serves as the entrance slit of Monochromator II. The radiation is reflected via mirror M6 to the appropriate grating on grating table G2 and then back via mirror M6 through the exit slit to Mirror M7. The rotational position of grating table G2 is synchronized to that of grating table G1. The radiation emerging from the exit slit exhibits high spectral purity with an extremely low stray radiation content.

In the UV/Vis and NIR range a choice is provided between a fixed slit width, a servo slit, and a slit program. When the servo slit is selected, the slit widths change automatically during scanning to maintain constant energy at the detector.

From mirror M7, the radiation beam is reflected via toroid mirror M8 to the chopper assembly (C). As the chopper rotates, a mirror segment, a window segment and two dark segments are brought alternately into the radiation beam.

When a window segment enters the beam, radiation passes through to mirror M9 and is then reflected via mirror M10 to create the reference beam (R).

When a mirror segment enters the beam, the radiation is reflected via mirror M10' to form the sample beam (S).

When a dark segment is in the beam path, no radiation reaches the detector, permitting the detector to create the dark signal.

The radiation passing alternately through the sample and reference beams is reflected by mirrors M11, M12, M13, and M11', M12', M13', respectively of the optics in the detector assembly onto the appropriate detector. Mirror M14 is rotated to select the required detector. A photomultiplier tube (PMT) detector is used in the UV/Vis range, while a lead sulfide (PbS) detector is used in the NIR range. Detector change is automatic during monochromator slewing.

At the cell plane, each radiation beam is approximately 12 mm high. The width of the radiation beams is dependent on the slit width. At a slit width of 5 nm each radiation beam is approximately 4.5 mm wide. To permit minimum sample volumes to be measured in micro cells, the height of the radiation beam must be reduced in the active cell area.

A common beam mask (CBM) is mounted between the slit assembly (SA) and mirror M7. This mask restricts the cross-section of both the sample beam and the reference beam in the respective cell area. The radiation beam can be reduced from the maximum height of 11.7 mm to 0.0 mm in 50 steps.

During all scanning operations, the monochromators stop slewing while a filter, source, or detector change is in progress.

NOTE: You can select the source or detector change wavelength within a defined wavelength range. This facility is useful if a feature of special spectral interest is located at one of the default change wavelengths.

The spectrometer scans from higher toward lower wavelengths.

There is an optional depolarizing filter (DP) accessory, which can be swung into the beam.

There are internal attenuators for the Lambda 850 and 950 spectrometers that can be swung individually into the sample beam (SBA) and the reference beam (RBA). The attenuators have the values: 0%, 1%, 10% and 100%. The Lambda 650 and 750 spectrometers require manual attenuators to be placed as needed (L6020277 – 10% attenuator, L6020276 – 1% attenuator).

Lambda 1050 Spectrometer

The optical system of the Lambda 1050 is the same as for the Lambda 950 spectrometer, with three exceptions.

First, there is a source doubling mirror M0 in the lamp compartment, designed to increase the intensity of the light from the halogen lamp (HL) that is reflected by mirror M1 to mirror M2.

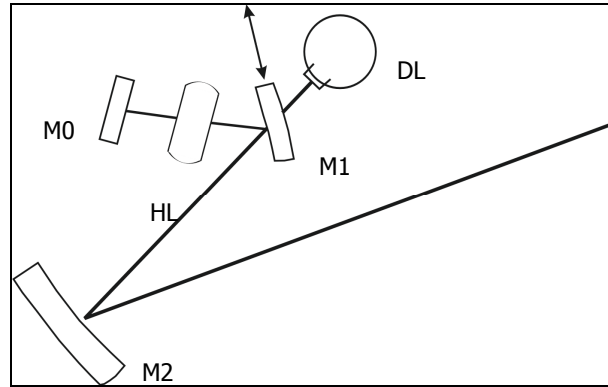

Figure 9 Optical system in the Lambda 1050 spectrometer lamp compartment

Second, the internal sample beam and reference beam attenuators have the possible values: 0%, 0.1%, 1% and 100%.

Third, the detector compartment has the Three Detector Module fitted as standard. A photomultiplier tube (PMT) detector is used in the UV/Vis range (175–860 nm). In the NIR range you will have either a narrowband or a wideband InGaAs detector (860–1800 nm or 860–2500 nm, respectively) and a lead sulfide (PbS) detector (860–3300 nm).

NOTE: The Three Detector Module is installed as standard in the Lambda 1050, but can also be purchased as an accessory for the Lambda 950. For more details see the *Three Detector Module User's Guide* (L6050010) on the *High-Performance Lambda Spectrometers User Manuals CD* (L6050009).

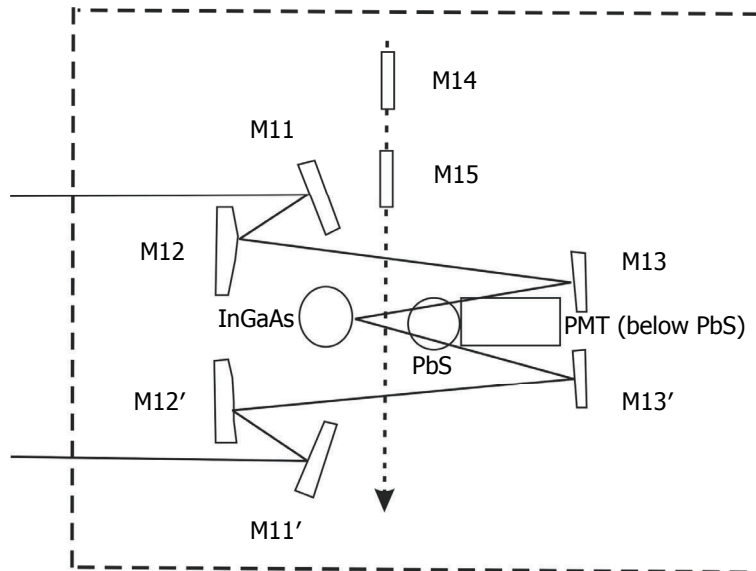

Figure 10 Optical system in the Lambda 1050 spectrometer detector compartment

The radiation passing alternately through the sample and reference beams is reflected by mirrors M11, M12, M13, and M11', M12', M13', respectively of the optics in the detector assembly onto the appropriate detector.

Mirrors 14 and 15 are used to select the appropriate detector. The mirror translation unit (Figure 11) has three positions. At position 1, mirror M14 (the aluminum, SiO₂-coated mirror) directs the beam to the PMT detector at the base of the compartment. At position 2, both mirrors are outside of the beam path, and the beam goes to the InGaAs detector. At position 3, mirror M15 (the gold mirror) directs the beam to the PbS detector at the top of the optics compartment. The changeover between the detectors occurs at predefined wavelengths, and is controlled by the software.

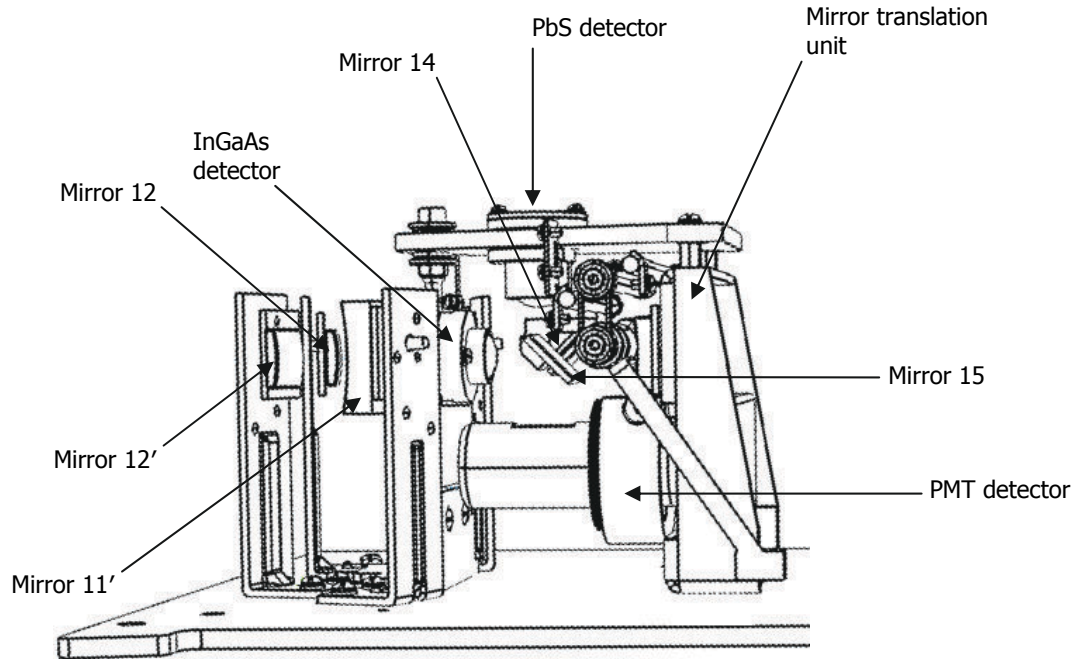

Figure 11 The arrangement of the detectors of the Three Detector Module



Installing your Lambda
Spectrometer

Overview

NOTE: The first-time installation of your instrument will be carried out by a PerkinElmer Service Engineer. The following information is for reference only.

Site Requirements

For maximum stability and minimum maintenance, observe the following requirements when choosing where to site the instrument:

- A firm base, free from vibration;
- Enough space around and underneath the instrument for efficient air circulation, as shown in Figure 12;
- A constant temperature between 15 °C and 35 °C;
- A constant relative humidity of between 20% and 80%;
- An atmosphere free from dust and corrosive fumes;
- Keep out of direct sunlight. Illumination with diffuse lighting is ideal;
- A suitable source of electrical power should be located in the vicinity of the instrument, in this case a proper earth-grounded 3-wire electrical outlet. The power requirements are 90 VAC–250 VAC, 50/60 Hz, 250 VA;
- The standard sample compartment baseplates have drain holes in them to run off spilled liquids to the benchtop underneath the instrument. If required, place a sheet of thick filter paper under the instrument.

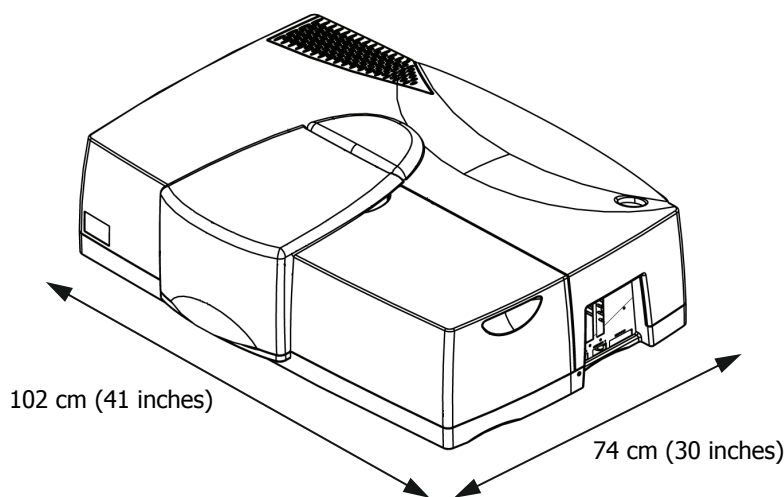

Figure 12 Space requirements

Unpacking

CAUTION

Take great care when installing your Lambda spectrometer, and follow the procedures described in this manual. If you require assistance, contact your PerkinElmer Service Engineer.



WARNING

The instrument weighs about 77 kg. Four people are needed to lift the instrument.

1. Unpack the components carefully, using four people to lift the instrument itself. Keep the packing materials for possible future storage or reshipment.

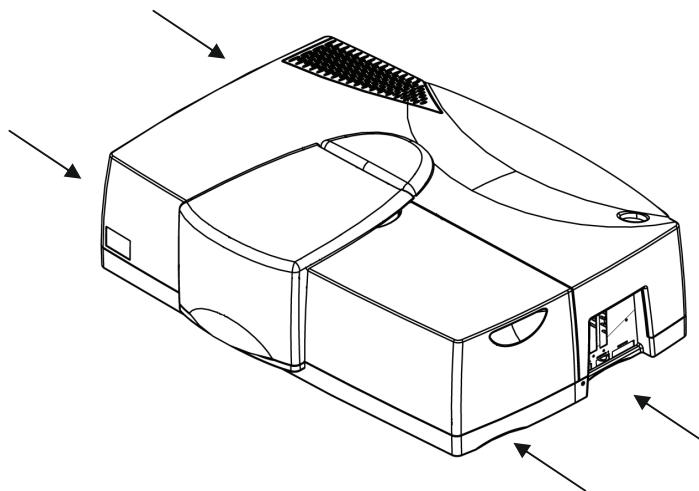

Figure 13 Position of hands beneath the instrument for lifting the instrument

2. Check that you have the items listed in the following table.

Part Number	Description
N/A	UV WinLab Software Kit (ES or Standard)
L6050007	<i>High-Performance Lambda Spectrometers Getting Started Guide</i>
L6050009	<i>High-Performance Lambda Spectrometers User Manuals CD</i>
B0505071	2 single-cell holders
B0142227	Screwdriver 5.5 mm
B0126972	Screwdriver 4.0 mm
B0859227	Long crosshead screwdriver
B0180242	Connecting cable, spectrometer to PC
B00507656	Spare fuse drawer
B0508454	Ferrite choke
B0155573	Spare fuses (10 × 3.15 A T)
L6020277	2 × 10% manual attenuators
L6020276	2 × 1% manual attenuators
B0505071	2 single-cell holders
N/A	Country-specific power lead

NOTE: The two manual attenuators are supplied only with a Lambda 650 or 750 spectrometer.

3. Examine the components for any signs of damage in shipment:

- Check the entire outer cabinet of the spectrometer for damage, and make sure that the terminals, fuse holders and so on are not damaged.
- Open and close the sample compartment cover, checking that it moves freely without binding.
- Make sure that the compartment is free of dust or other foreign matter.

NOTE: In the event of damage or missing parts, file an immediate claim with the authorized carrier, and inform your PerkinElmer office or representative.

Connecting to the Line Power Supply



Electrical Hazard

To prevent potential injury to yourself and damage to the instrument, make any electrical connections in the system before connecting to the line power supply.

The spectrometer automatically adjusts to the correct operating voltage.

Before starting the instrument for the first time, make sure that the correct fuse is fitted to your line power supply.

- *If you have a different fuse, change it for the correct one.*
- *Do not connect the spectrometer to the line power supply if the wrong fuse is fitted.*

1. Make sure that the correct fuses are fitted in the holder at the rear of the spectrometer (see *Fuses* on page 22).

NOTE: The module has two fuses.

2. Make sure that the plug fitted to the line power cord provided with the spectrometer is suitable for your local electrical outlets.
If it is not, remove it and fit a plug conforming to the local regulations.
3. After all connections have been made between the various components of the system, make certain that all power switches are set to OFF, then connect the line cords to the electrical power supply.
The power switch is located at the top right-hand rear of the spectrometer.

NOTE: To prevent interferences caused by earth loops when operating with ancillary instruments (for example, printers), connect all components of the system to the same phase of the electrical supply via a multisocket distributor.

Connecting the System Components



Electrical Hazard

*To prevent potential injury to yourself and damage to the instrument, switch **OFF** all instruments in the system and disconnect them from the line power supply before you alter any, or make any new, electrical connections.*

- The PC and the printer may be placed either side of the spectrometer, but must not be placed on top of the spectrometer.
When placing instruments side by side, always leave a small gap between them.
- Make sure that air can circulate freely over and under the system, as well as behind it.
- Do not place anything on, or under, any of the components that could hinder free air circulation.

Connecting to the PC

- The PC is connected using the connection marked COMPUTER on the right side of the instrument, as shown in Figure 14.

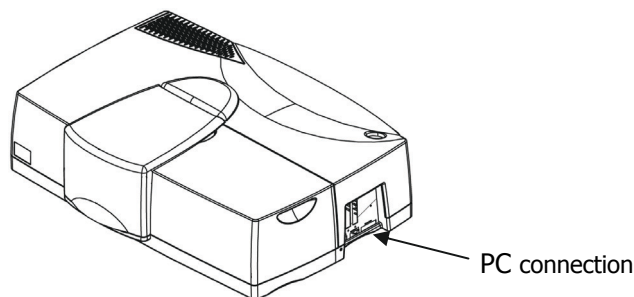

Figure 14 PC Connection

NOTE: You can use an external printer for hard-copy printouts of the analytical results. The printer is connected via the PC.

Setting up the Instrument in the Software

Before you can use your instrument with UV WinLab software, you must set up the instrument in the UV WinLab Explorer.

NOTE: For instructions on how to install the Standard version of the UV WinLab software, see the *High-Performance Lambda Spectrometers Getting Started Guide* (L6050007). For instructions on the installation and use of the Enhanced Security version, see the *UV WinLab (ES) Administrator's Guide* (L6050012) provided with your software.

NOTE: If your instrument is installed by a PerkinElmer Service Engineer, you should not need to do this. You will require permission to configure instruments to add a new instrument.

1. With the instrument switched on, from the **Folder List** in the UV WinLab Explorer Window select **Instruments**.

The Instruments pane is displayed.

2. Double-click **Add New Instrument**, .

The New Instrument Wizard starts.



3. Select the **High performance UV/Vis/NIR instrument** from the **Choose the type of instrument** from the drop-down list.

The **Description** below the drop-down list details the available instruments for the selected type.

4. Click **Next**.

The Select Instrument Type page is displayed.

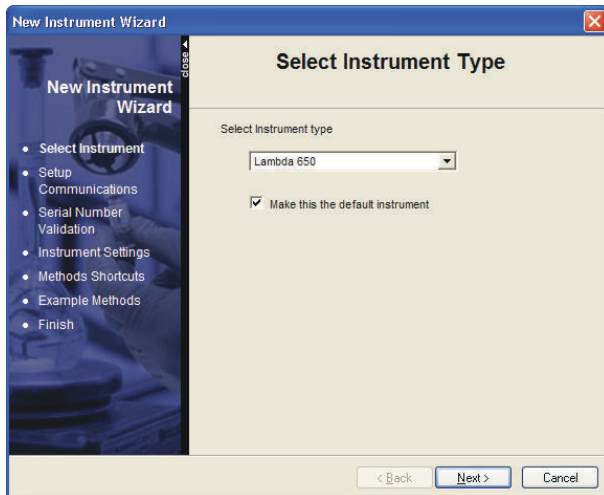

5. Select the appropriate instrument (in this case the **Lambda 650**) from the drop-down list and, if required, select **Make this the default instrument**.
6. Click **Next**.
The Setup Communications page is displayed.

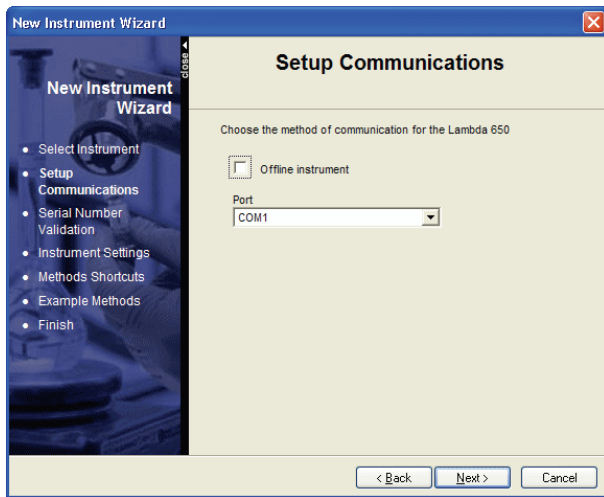

7. From the drop-down list, select the **Port** the instrument is connected to.
8. Click **Next**.
The software will automatically perform a check to see if the correct instrument is attached to the selected port and switched on, and will display a warning message if not.
You may then be asked to confirm the serial number of the instrument.

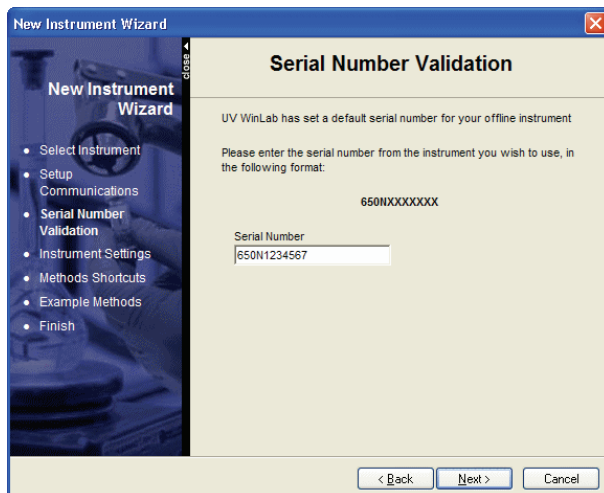

9. Check the serial number on the right-hand side of the instrument, where the PC connects to the instrument, correct it if necessary, and then click **Next**.
The Install Lambda 650 page is displayed.



10. Enter a **Name** for the instrument.
The **Name** you enter will be displayed in the UV WinLab Explorer beneath the instrument icon. It can be edited in future if required.
11. Select whether a **Common Beam Depolarizer** and/or **Double Polarizer/Depolarizer** are installed.
These can be selected if you are going to use them, even if they are not currently installed.

NOTE: If you are installing a Lambda 850, 950 or 1050 spectrometer, which have automatic attenuators, then the option **Sample/Reference Beam Attenuators** option is also available. The Lambda 650 and 750 spectrometers have manual attenuators only.

NOTE: The Common Beam Depolarizer and Sample/Reference Attenuators need to be enabled on the **Instrument** tab of the **Instrument Properties** dialog. Select **Enable common beam depolarizer** or **Enable Internal attenuators**. Do not alter the instrument properties unless you fully understand the implications of doing so.

12. Click **Next**.

The Methods Shortcuts page is displayed.

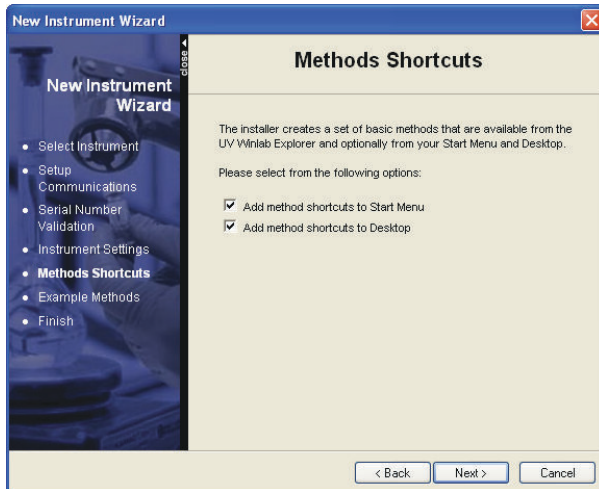

13. Select your Method shortcut options.

UV WinLab can install shortcuts to the Method options on to the Windows Start menu and on to your Desktop, as required.

All options are selected by default.

14. Click **Next**.

The Example Methods dialog is displayed.

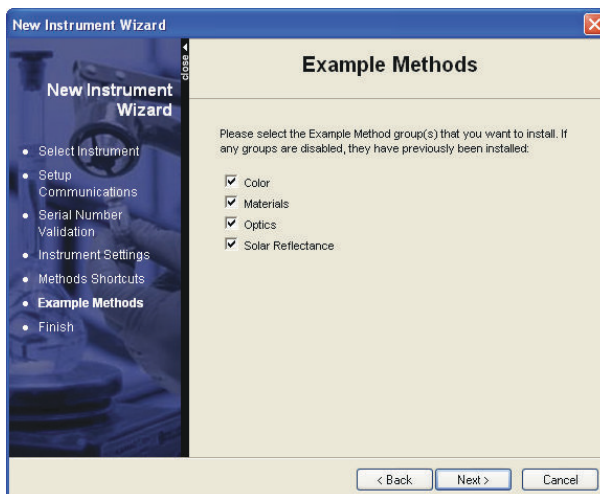

15. Select the group(s) of Example Methods that you would like to install.
The groups include: **Color**, **Materials**, **Optics** and **Solar Reflectance**.

16. Click **Next**.

The Finish page displays all the selected settings.



17. If all the settings are correct, click **Finish** to close the wizard and add the instrument. The Wizard closes, a confirmation message that the instrument has been successfully installed is displayed, and the instrument is displayed in the UV WinLab Explorer (after a few moments).

OR

Click **Back** to return to the previous page(s) and amend the settings as required.

NOTE: For instructions on installing the Three Detector Module software, and using the detector module with UV WinLab, see the *Three Detector Module User's Guide* (L6050010) on the *High-Performance Lambda Spectrometers User Manuals CD* (L6050009).

Calibrating the Instrument

Once the instrument is set up in the software you will need to calibrate it.

NOTE: Make sure that the instrument has been switched on for at least an hour before calibrating it.

1. From the Instruments pane of the UV WinLab Explorer Window, click the right mouse button on the new instrument and select **Calibrate Instrument**.
The Calibration Utility dialog is displayed.
This dialog displays the names of the routines, a description, the last calibration date of the routine, and whether the test is enabled.
2. Select the routines to be performed by the calibration.
There are three calibration routines available for the Lambda 650/850 spectrometer: **UV/Vis Wavelength**, which calibrates the UV/Vis wavelength range, **Slits**, and **0%T**, which calibrates the electronic offsets.
There are four calibration routines available for the Lambda 750/950/1050 spectrometer: **UV/Vis Wavelength**, which calibrates the UV/Vis wavelength range, **NIR Wavelength**, which calibrates the NIR wavelength range, **Slits**, and **0%T**, which calibrates the electronic offsets.
All of these routines should be performed.
A check mark indicates the routine is selected and will be performed.

- To view (and change) the settings for a particular routine, highlight the routine in the table and then click **Settings**.

The Settings dialog for the selected routine is displayed.

NOTE: Settings is not available for Slits.

- Select the options for each calibration routine.

UV/Vis Wavelength:

- Manual set** enables you to enter the **offset** and **factor** (without the need to determine the values in advance).
- Manual set 1 peak** enables you to change the offset. A well known peak can be shifted to an exact wavelength by entering values of **Old Peak 1** and **New Peak 1**.
- Manual set 2 peaks** enables you to change the offset and factor by specifying the old and new values of 2 well known peaks by entering values of **Old Peak 1**, **New Peak 1**, **Old Peak 2** and **New Peak 2**.
- Auto search 1 peak** enables you to change the offset. The software performs an automatic search for the D₂ peak at 656.1 nm. The measured peak is then shifted to the exact wavelength.
- Auto search 2 peaks** enables you to change the offset and factor. The software performs an automatic search for the D₂ peak at 656.1 nm and the peak at 0.0 nm. The measured peaks are then shifted to the exact wavelengths.

NOTE: Auto search 2 peaks is the default setting.

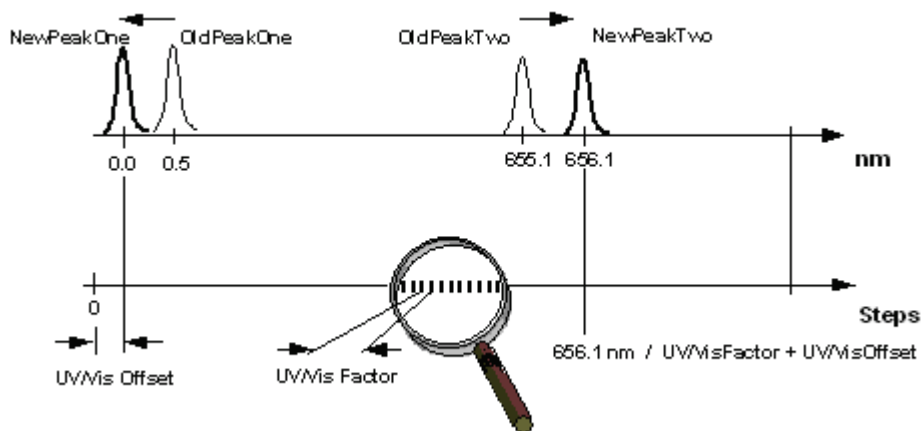

NIR Wavelength:

- Select **Manual set**, **Manual set 1 peak**, **Manual set 2 peaks**, **Auto search 1 peak**, or **Auto search 2 peaks**.
- Manual set** enables you to enter the **offset** and **factor** (without the need to determine the values in advance).
- Manual set 1 peak** enables you to change the offset. A well known peak can be shifted to an exact wavelength by entering values of **Old Peak 1** and **New Peak 1**.

- **Manual set 2 peaks** enables you to change the offset and factor by specifying the old and new values of 2 well known peaks by entering values of **Old Peak 1, New Peak 1, Old Peak 2** and **New Peak 2**.
- **Auto search 1 peak** enables you to change the offset. The software performs an automatic search for the D₂ peak at 1312.2 nm. The measured peak is then shifted to the exact wavelength.
- **Auto search 2 peaks** enables you to change the offset and factor. The software performs an automatic search for the D₂ peak at 1312.2 nm and the peak at 0.0 nm. The measured peaks are then shifted to the exact wavelengths.

NOTE: Auto search 2 peaks is the default setting.

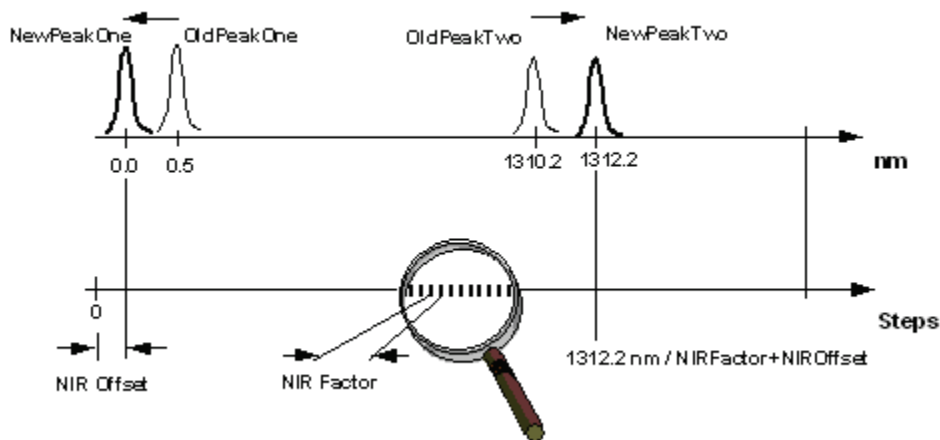

Slits:

There are no user-defined settings in the slit calibration.

0%T:

Auto enables the software to determine the required offset.

OR

The required **Calibration offset** value can be entered.

5. Click **Calibrate**.

The calibrations are performed in the order listed in the table. Messages below the table show the progress of the calibration.

When a calibration has passed, a green check mark is displayed in the first column of the table. If the test fails, a red cross is displayed. In such an event please contact your local PerkinElmer Service Engineer.

6. When the calibration has finished, click **Close** to close the dialog.

The date and time of the calibration are recorded in the instrument event log.

NOTE: It is not possible to print the calibration results.

Your instrument is now ready to be used.

Installing Accessories



Electrical Hazard

*To prevent potential injury to yourself and damage to the instrument, switch **OFF** all instruments in the system and disconnect them from the line power supply before you alter any, or make any new, electrical connections.*

NOTE: To operate the spectrometer with some accessories, for example Peltier cell changers, you need an accessory printed circuit board (PCB) fitted in the connector panel. The accessory PCB will be installed by a PerkinElmer Service Engineer.

This section of the manual details changes that may need to be made to the basic spectrometer before installing an accessory and an overview of the installation required for some of the specific accessories. Full procedures for installing the accessories in the spectrometer are described in the documentation provided with the respective accessories.

Removing the Parts of the Sample Compartment

Removing the Sample Compartment Cover

1. Open the sample compartment cover so that the lid is at 90 degrees.
2. Push back on the base of the lid to release the three lugs holding it in place.

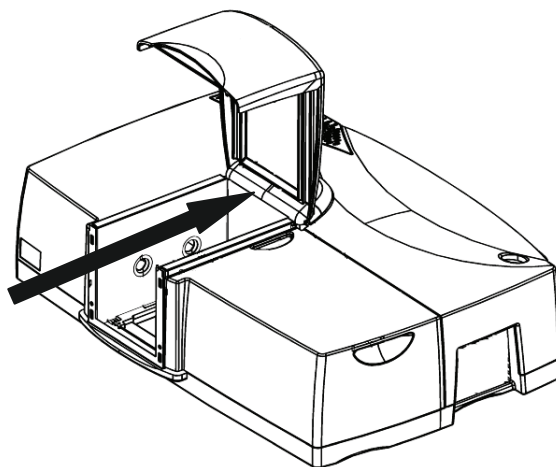

Figure 15 Opening the sample compartment to reveal the three lugs

3. Lift the whole lid vertically to remove.

NOTE: To refit the lid, make sure that the lugs are properly inserted into the holes, and then holding the lid vertically, pull it towards the front the instrument making sure that the lugs are fully locked into place.

Removing the Sample Compartment Windows

- Each window has a magnetic frame and can be removed carefully by hand.
Replace the window in its original position.

Removing the Sample Compartment Baseplate

1. With the sample compartment cover open or removed, undo the four thumbscrews shown in Figure 16.

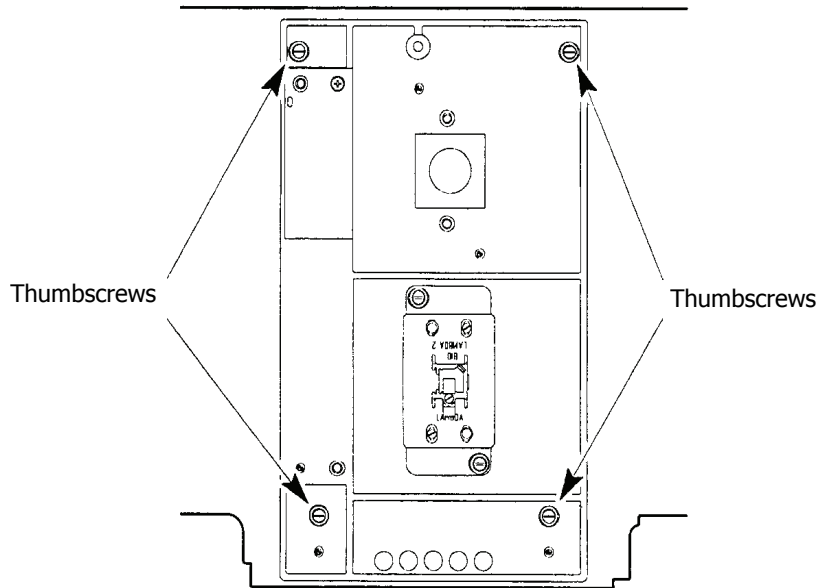

Figure 16 Four thumbscrews on the sample compartment baseplate

2. Lift the baseplate up and off the locating pins, and remove it from the sample compartment.

Removing the Sample Compartment

1. After removing the sample compartment cover and baseplate as described above, undo the four retaining screws shown in Figure 17.

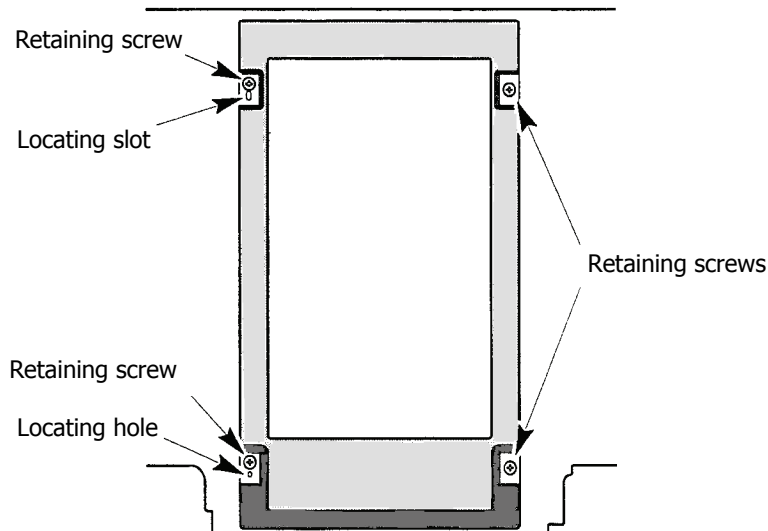

Figure 17 Four retaining screws in the sample compartment

2. Lift up the sample compartment off the locating pins and remove it from the spectrometer.

Removing the Detector Unit



Electrical Hazard

The connector for the detector unit carries high voltage (130 V dc). Switch off and disconnect the instrument before removing or fitting a detector/accessory unit.

1. Switch off the spectrometer and disconnect the line power cord.
2. Open the sample compartment cover.
3. Undo the two retaining screws located under the blanking caps on the top of the detector (Figure 18), which are accessible using the long, posidrive screwdriver supplied with the instrument.

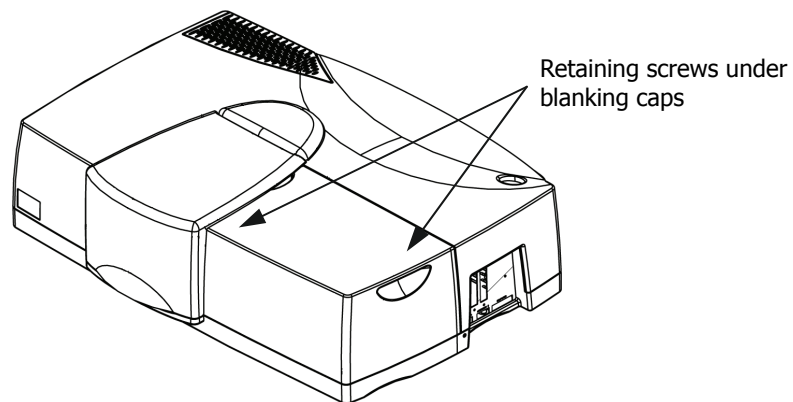

Figure 18 Undoing the retaining screws

4. Remove the detector compartment cover by carefully lifting vertically using the two hand holds, as shown in Figure 19.

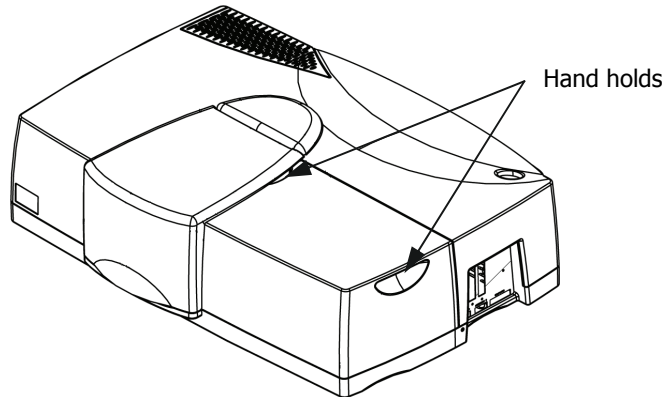

Figure 19 Removing the detector compartment cover

5. Move the detector unit carefully to the right and remove it from the spectrometer. The detector unit is installed by performing this procedure in reverse, tightening the retaining screws and making sure the blanking caps are in place.



WARNING

Make sure you screw down the detector unit as this creates the earth bonding for electrical safety.

Details of the installation procedure for a sphere, the Three Detector Module or the Universal Reflectance Accessory (URA) are given in the relevant manual on the *High-Performance Lambda Spectrometers User Manuals CD (L6050009)*.

Accessory Connector Panel

The accessory panel is fitted with an RS 232 interface and two 15-pin connector sockets. There are also three slots for the accessory printed circuit boards (PCB) for those accessories that require them.

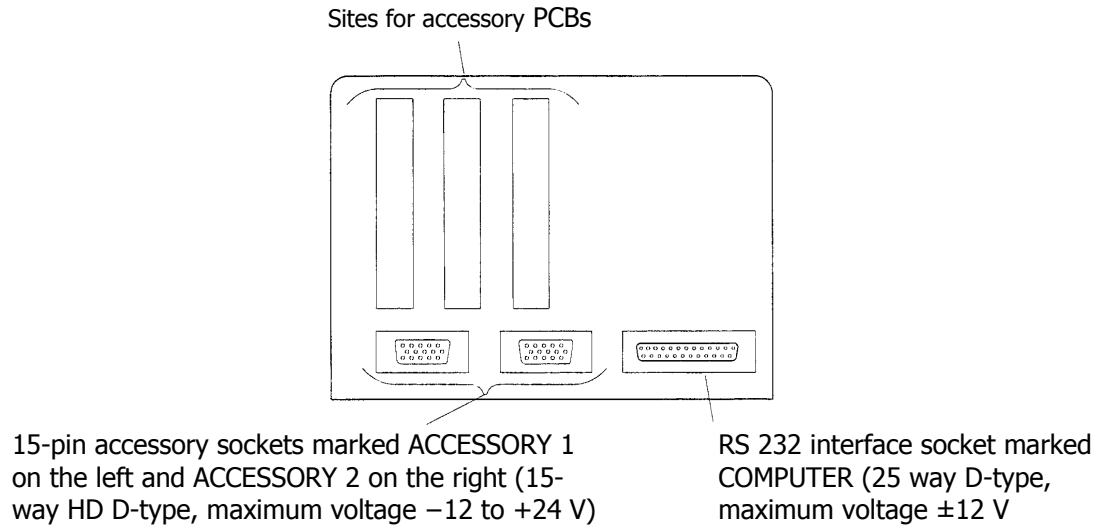

Figure 20 Connector panel for accessories

NOTE: The insulation of externally connected accessories should meet the requirements of IEC 61010-1 or IEC 60950.

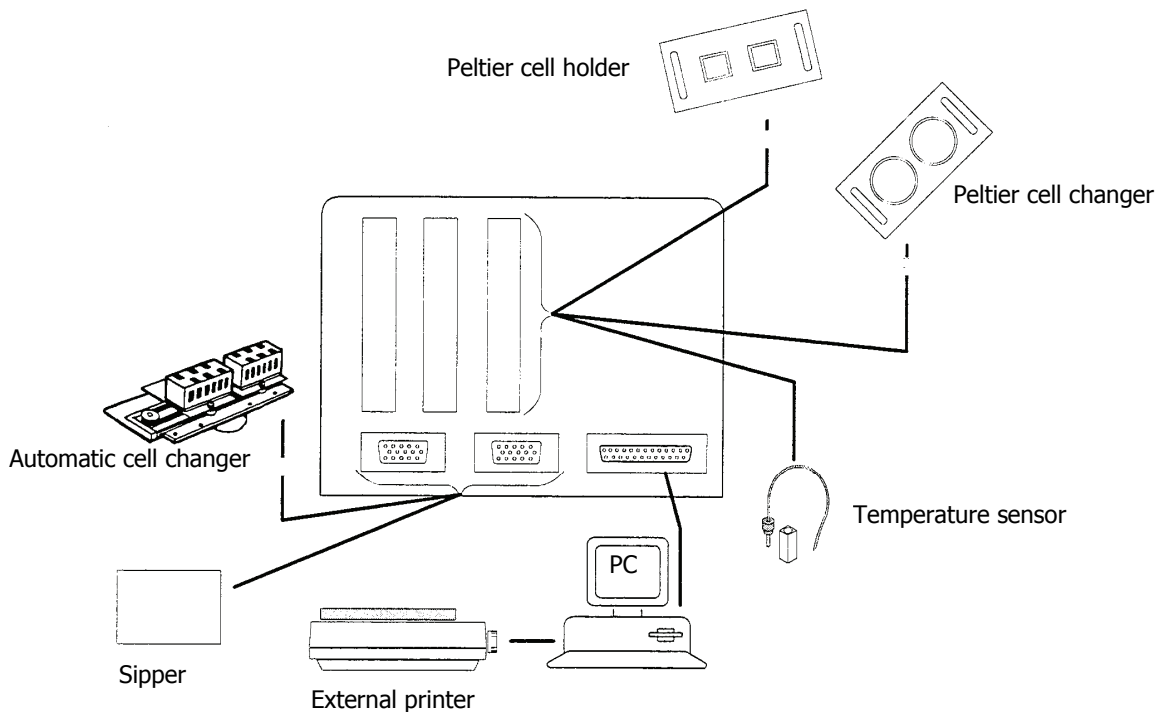

Figure 21 Possible accessories for your high-performance Lambda spectrometer

The Polarizer/Depolarizer accessory also fits into the 15-pin accessory sockets.

Overview of Accessory Installation

NOTE: The spheres, Three Detector Module and the URA Accessory are covered in separate manuals. See the *High-Performance Lambda Spectrometers User Manuals CD* (L6050009).

Automatic Cell Changers

Connector on Spectrometer:	15-pin connector
Installation:	See the cell-changer manual
Cables:	Lead through bottom of spectrometer housing
Tubes:	Lead through bottom of spectrometer housing
Sample compartment cover:	Unchanged
Alignment:	See cell changer manual

Temperature Sensor

Connector on spectrometer:	Slot in accessory board
Installation:	See temperature sensor description
Cables:	Lead through the tube ports
Sample compartment cover:	Unchanged

NOTE: When connecting the temperature sensor, align the red mark on the plug with the red mark on the socket. Pull back the collar on the plug to connect/disconnect the plug. Release the collar to secure the plug.

Sippers

Connector on spectrometer:	15-pin connector
Installation:	See sipper manual
Cables:	See sipper manual
Tubes:	See sipper manual
Sample compartment cover:	Install the special sample compartment front plate and cover

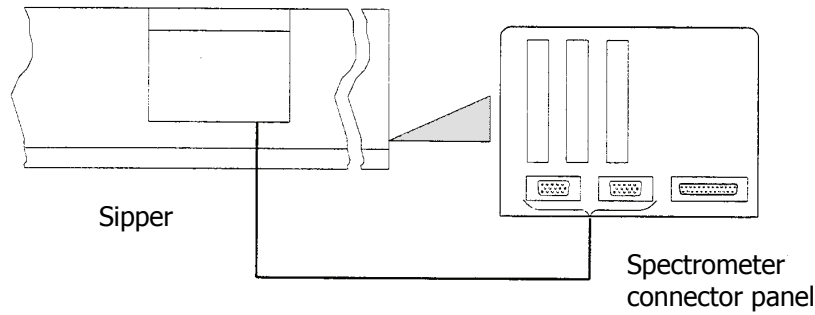

Figure 22 Sipper electrical connection

Pin Configuration

There are two 15-pin connectors fitted to the connector panel of the high-performance Lambda spectrometer for the connection of accessories. The connectors are identically configured so that the accessories can be connected to any of them. The pin numbering is shown in Figure 23, and the configuration is given in the following table.

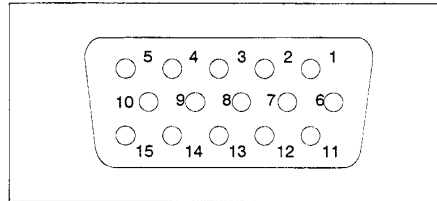

Figure 23 Pin configuration of 15-pin connector

Pin	Configuration	Description	Pin	Configuration	Description
1	GND D	Ground (Digital) logic	9	Not used	
2	+5 V	Logic power supply	10	Not used	
3	Not used		11	+12 V	Analog power supply
4	GND P	Ground Power	12	GND A	Ground Analog
5	+24 V	Power Supply	13	-12 V	Analog power supply
6	Not used		14	SCL	Serial clock
7	Not used		15	SDA	Serial data
8	Not used				

Using the Spectrometer

Startup Procedure

NOTE: If you have purchased any accessories, then you may want to install these first before commencing with the Startup procedure. An overview of the available accessories is on page 51. See also the specific documentation for the accessory.

CAUTION

Do not turn power to the instrument on and off quickly as this may damage the power supply.

Wait at least 30 seconds before restarting the instrument.

1. Open the sample compartment cover.
2. Make sure that the beam paths are free from obstruction.
This means that no objects (for example, cables) project into the beam paths, no samples are in the sample compartment, and any accessories are properly installed.

NOTE: If the sample compartment is obstructed during the startup procedure, the spectrometer will not initialize correctly.

3. Close the sample compartment cover.
4. Switch on the power switch located at the top right-hand corner of the instrument, as shown in Figure 24.
The switch will light up when there is power to the instrument.

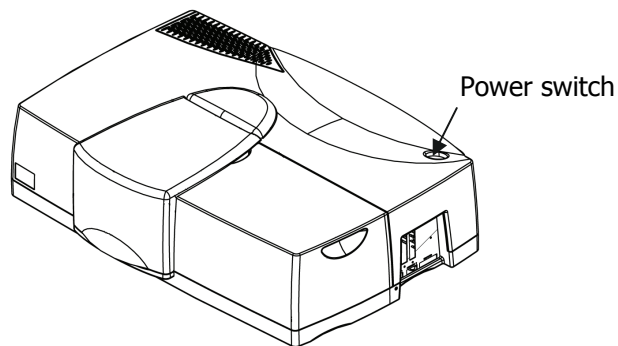

Figure 24 Power switch

5. Switch on any accessories.
6. Wait until all instrument initialization is complete.
This will take approximately three minutes from switching the power on.
7. Start the UV WinLab software.

NOTE: We recommend for optimal performance of the instrument that you should leave the spectrometer switched on for approximately one hour to allow the lamps to warm up and stabilize before starting analysis.

The Single-Cell Holder

Description

There are two single-cell holders provided with the instrument (see Figure 25): one for the sample beam and one for the reference beam. The single-cell holders are mounted on a plinth to bring them in line with the radiation beam.

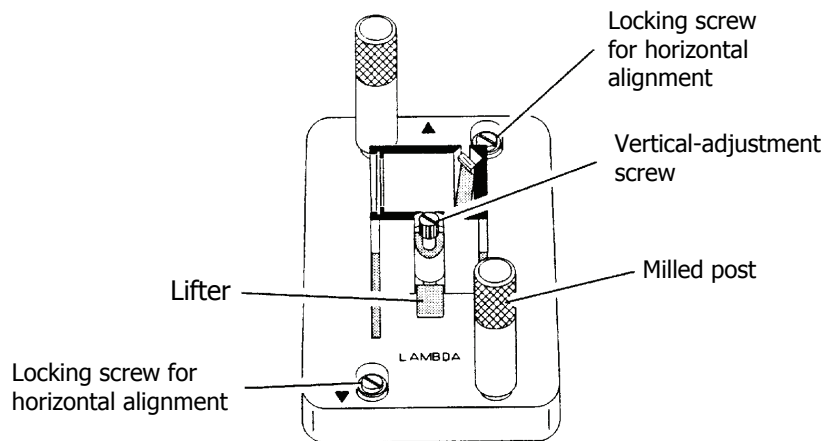

Figure 25 Single-cell holder B0505071

Installing the Single-Cell Holder

To install the plinth in the sample compartment:

1. Lower the plinth so that the two locating holes slip onto the two locating pins on the baseplate in the sample compartment, as shown in Figure 26.
The plinth fits one way round only.

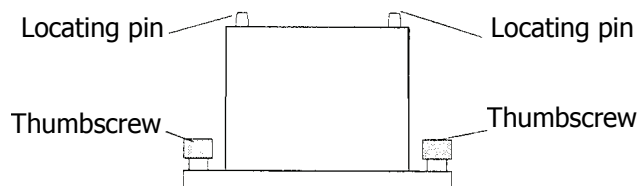

Figure 26 Fitting the plinth to the baseplate in the sample compartment

2. Screw the two thumbscrews by hand into the baseplate.

To install the single-cell holder in the sample compartment:

1. Orientate the holder so that the word **LAMBDA** is toward the front of the sample compartment (see Figure 27).
2. Lower the holder so that the two locating holes slip onto the two studs on the two locating pins on the plinth in the sample compartment.
The cell holder fits one way round only.

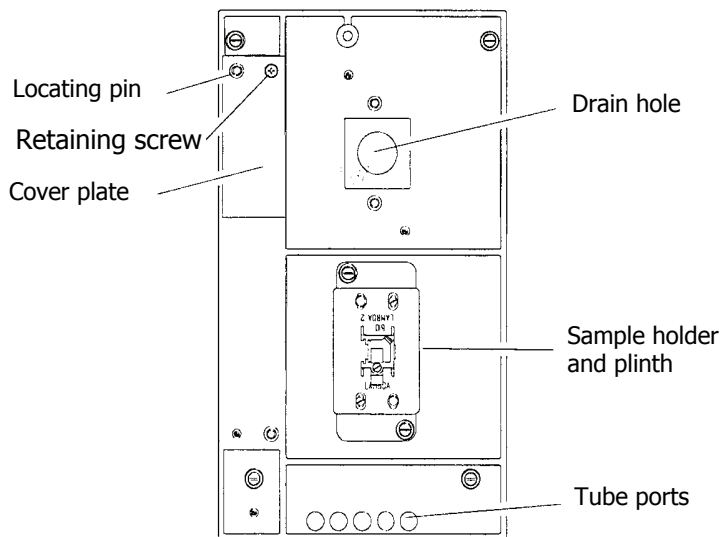

Figure 27 Baseplate of the high-performance Lambda spectrometer sample compartment

3. Move the milled posts a little to locate the threaded holes in the baseplate and then tighten the milled posts.
You can lead tubes and connecting cables for accessories into the sample compartment through either the tube ports, located at the front of the sample compartment, or the opening located at the left rear of the sample compartment, under the cover plate.
When not in use, you should always insert the caps into the tube ports and keep the cover plate fixed in place.
The cover plate is fixed in place by a retaining screw.

Aligning the Single-Cell Holder

To carry out the coarse alignment of the single-cell holder:

1. Open the sample compartment cover.
2. Fill the cells with a low-absorbing solvent (deionized water or ethanol).
3. Insert one cell into the sample-cell holder and one into the reference-cell holder.
Make certain that the cell is pushed down fully.

NOTE: The alignment procedure is for a given cell in a given holder. After alignment, the cell should always be used in the same holder.

4. From the UV WinLab Explorer window, select the instrument you are using and select **Manual Control** from the Tools menu.
5. From the Manual Control window, select **Data Collection** from the Folder List and then select the **Alignment Mode** check box.
6. Block the sample and reference beam windows on the right side of the sample compartment with a card to prevent white light from saturating the detector.
7. By holding a piece of matt white paper behind each cell holder, visually examine the light spot to see whether the radiation beam is passing through the cell sample area. Diffraction patterns become apparent if the radiation beam impinges on the cell wall.
8. If the radiation beam is not centered exactly, loosen the two locking screws and the two milled posts on the relevant cell holder, and shift the cell-holder plate to center the radiation beam. Then retighten the two milled posts and the two locking screws.
9. Visually check the vertical alignment of the radiation beam in the cell sample area. Alignment is correct when the radiation beam is just above the floor of the cell sample area (minimum 2 mm) or covers the cell window, as shown in Figure 28.

NOTE: The center of the window for micro flowcells should be ideally approximately 15 mm above the base of the cell.

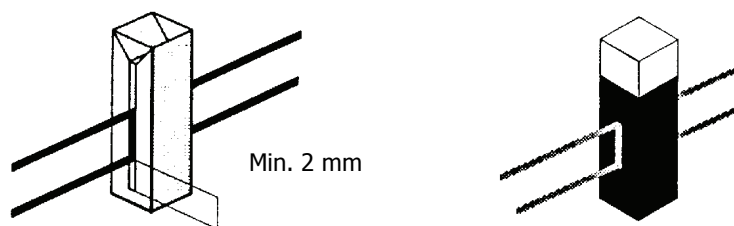

Figure 28 Correct alignment of the radiation beam in the cell sample area

10. If alignment is required, turn the vertical adjustment screw on the lifter either clockwise to raise the cell, or counterclockwise to lower the cell.
11. Recheck the horizontal alignment of the radiation beam through the cell and correct if necessary.
12. Slew the monochromator to any value above 200 nm.
13. Remove the card blocking the sample beam window and close the sample compartment cover.
This completes the coarse alignment of the cell holders. If necessary, proceed with the fine alignment as described below.

Fine Alignment

If fine alignment is necessary, proceed as follows:

1. Slew the monochromator to your measurement wavelength or to 460 nm.
2. Call up a method that uses transmission (%T) as the ordinate.

OR

If necessary change the ordinate mode to transmission.



3. Remove the reference cell from the sample compartment.
4. Make horizontal fine alignment adjustments to the sample cell holder (locking screws and milled posts loosened) to obtain the highest possible transmittance reading on the display.
Close sample compartment cover while measuring transmittance.
5. Make fine alignment adjustments using the vertical adjustment screw, again to obtain the highest possible reading.
Close sample compartment cover while measuring transmittance.
6. When you are satisfied with the alignment, tighten the milled posts and the locking screws on the cell holder.
7. Reinstall the reference cell in the reference cell holder.
8. The sample cell remains in its holder.
9. Repeat steps 4 to 6 with the reference cell holder, but this time obtain the lowest possible transmittance reading on the display.
This completes the fine alignment procedure.

<p>NOTE: When the cell holder has been aligned once, you can take it out and reinstall it without aligning it again.</p>

Minimum Volume Applications

To measure minimum sample volumes, use microcells (offered by PerkinElmer).

The minimum sample volume required is a function of the internal width, or volume, of the cell and is specified in the following table.

Cell Type		Cell Internal Width	Pathlength	Minimum Volume Required	Part Number
	Height of liquid slightly more than height of beam	2 mm	1 cm	150 μL	B0079404 (pair)
		4 mm	1 cm	300 μL	B0079402 (pair)
		Cell Volume	Pathlength	Minimum Volume Required	Part Number
	Cell window completely filled with liquid	0.5 μL	0.01 cm	2 μL	B0510076
		2.5 μL	0.5 cm	5 μL	B0510077
		5 μL	0.1 cm	10 μL	B0510078
		5 μL	1.0 cm	10 μL	B0505823
		30 μL	1.0 cm	50 μL	B0190608

NOTE: You should align microcells very carefully in the radiation beam by following the procedures in *Aligning the Single-Cell Holder* on page 56. When aligning microcells, fill each cell with at least the minimum volume of liquid specified in the above table to make sure that the liquid meniscus is not in the radiation beam.

Purging the Instrument



WARNING

*Always purge the instrument with an inert gas such as nitrogen.
Never use a flammable gas such as hydrogen.*



WARNING

Do not site the instrument in a poorly ventilated area if nitrogen will be used as a purge gas.

Oxygen depletion in an enclosed space does not trigger a gasping reflex, and errors of judgment, confusion, or unconsciousness can occur in seconds and without warning.

NOTE: You cannot purge the Lambda 650 or 750 spectrometers.

Oxygen absorbs radiation in the UV range below 190 nm, while water vapor absorbs radiation in the NIR range between 1350 nm and 1450 nm, 1850 nm and 1950 nm, and also between 2520 nm and 3000 nm. Best accuracy for measurements in these spectral regions can be obtained only when the spectrometer is purged with nitrogen.

The entire optical compartment of the spectrometer is sealed. Radiation from the source lamps enters the optical compartments through a window. The sample compartment is also sealed from the optical compartment by windows. Thus the entire optical radiation path from virtually the source lamp to the detector can be purged largely free of water vapor and oxygen.

Fittings are provided on the left-hand side of the spectrometer for connection of a supply of nitrogen, as shown in Figure 29. The inlet nearest the rear of the instrument is for the sample compartment and the one nearest the front of the instrument is for the main optical compartment. After purging these compartments, the nitrogen escapes to atmosphere.

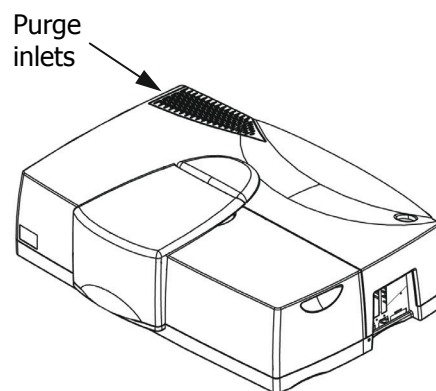

Figure 29 Connectors for the purge gas supply

You should keep the sample compartment closed during routine operation to prevent the water vapor and oxygen from entering. When performing operations within the sample compartment, do not leave the sample compartment cover open for any longer than is necessary. After closing the sample compartment, purge for several minutes before starting measurements.

When the spectrometer has been standing for some time unpurged, an initial flow of 20 L/min is recommended. After the spectrometer has been thoroughly purged, the flow can be reduced to between 6 L/min to 7 L/min.

When you have a good deal of work in a spectral region where water vapor or oxygen absorb the radiation, we recommend that you purge the spectrometer more or less continuously. This has the advantage that startup times are markedly shorter. This advantage is somewhat offset by the increased consumption of nitrogen.



Maintenance

Overview



Unauthorized Adjustments and Servicing

Do not attempt to make adjustments, replacements or repairs to this instrument except as described here. Only a PerkinElmer Service Engineer or a similarly trained and authorized person should be permitted to service the instrument. Please contact your local PerkinElmer sales or service office.

This chapter describes the routine maintenance procedures required to keep your instrument in proper working condition and to ensure the highest possible level of performance. It includes maintenance checks that should be done on a daily basis and maintenance procedures that should be done periodically, depending on instrument use. This chapter is divided into several sections, each section covering maintenance procedures for a particular component of the system.

You should perform only the maintenance procedures described in this chapter. If additional maintenance is required, contact a PerkinElmer Service Engineer.

CAUTION

Before using any cleaning or decontamination methods except those specified here, users should check with PerkinElmer that the proposed method will not damage the equipment.

Daily Checks

The instrument is constructed with high-quality components and requires little maintenance other than to keep it clean and free of dust.

To protect the optical system from dust and fumes, you should keep the sample compartment cover closed except for when you are carrying out work in the compartment. The sample compartment windows should always be installed.

You should observe the following care routine to maintain your instrument in good condition:

- Clean all spilled materials from the affected area immediately and wipe it dry with lint-free paper or cloth.
If you have to wipe the sample compartment windows, make sure you do not introduce scratches. The windows are optical components, and you should handle them in the same way as high-quality cells.
- Do not leave samples, particularly those given to fuming or evaporation, in the sample compartment for longer than necessary.
- If any type of sample handling system is installed and portions of it are left in the sample compartment (such as a sipper and flowcell), make certain that the system is cleaned at the end of the working day.
Generally, such systems should be filled with deionized water when left overnight.

CAUTION

Spills

Take care not to spill liquids onto the spectrometer. Expensive damage can result to the optics or electronics if liquids are spilled and run inside the instrument.

Cleaning the Instrument Covers

You can clean the outside of the instrument using a damp cloth. Mild detergent may be used, if necessary. Always perform a patch test on an inconspicuous area of the instrument before you clean the entire instrument.

Cleaning the Sample Compartment

You must clean the sample compartment every time anything is spilled into it. This preserves the matt-black finish, and prevents corrosion and contamination.

The standard sample compartment baseplates have drain holes in them, as shown in Figure 30, to allow spilt liquids to run-off to the benchtop underneath the instrument. If required, place a sheet of thick filter paper under the instrument.

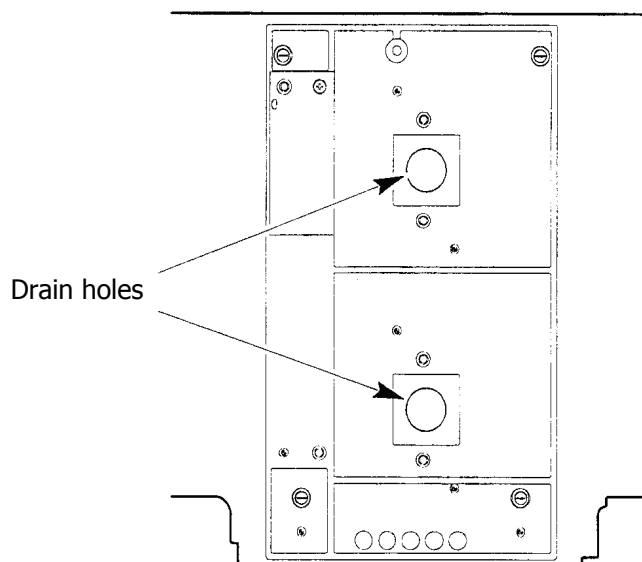

Figure 30 Drain holes in standard sample compartment baseplate

1. First remove the cell holder or other sample-handling accessory from the sample compartment.
2. Using a soft cloth and a solution of a mild laboratory detergent, lightly scrub away all foreign matter.
3. Using a clean cloth dampened with water, rinse the cleaned surfaces thoroughly.
4. Dry with lint-free cloth or tissue.

Sample Compartment Windows

Four windows are provided with the spectrometer. The windows are made of silica and may be used in the entire spectral range of the spectrometer.

The windows seal the sample compartment and thus protect the instrument's optics from dust and fuming or aggressive samples.

- Generally, the windows should be installed at all times.
- The windows are an optical component and require the same care and handling as cells.
- The windows can be removed to clean them. Each window has a magnetic frame and can be carefully removed by hand.

Windows are most suitably cleaned by wiping them with a soft cloth moistened with ethanol.

Replace the window in its original position after cleaning.

Use and Care of Cells

A good spectrometer cell is an optical device, forming a part of the optical system of the instrument with which it is used. It must be accorded the same careful treatment applied to any optical component. Optical faults of a minor nature, scratches, lint, finger marks, and so on, on the optical surfaces can easily introduce substantial analytical errors.

You should observe the following list of cell handling rules to prevent analytical errors and to achieve utmost precision:

- Only hold cells by non-optical surfaces, such as the matt finish surfaces.
- Protect cells from scratches, and never permit them to rub against one another or against other hard surfaces.
- Avoid abrasive, corrosive or stain-producing cleaning agents, and make certain that the exposed surfaces of cells are optically clean.
- Always wipe the optical surfaces of cells dry and free of finger marks, using a soft cloth or cleaning tissue, just before placing them in the cell holder.
- When measuring cold solutions, always bear in mind that condensation can form on the optical surfaces.
- Make certain no bubbles cling to the inner surfaces of the cell, particularly when handling cold solutions.

For maximum precision and accuracy, calibrate and test with cells of the same type, and always insert cells into the holders with the same orientation.

Replacing a Lamp

If a lamp failure warning message is displayed, or you are seeing excessive noise on the baseline, you can replace the lamps as follows.



Electrical Hazard

*High voltages are present at the lamp connectors in the lamp compartment – severe electric shock hazard.
Never unplug or plug in a lamp cable while the power is ON.
Switch off the spectrometer and remove the plug from the electrical supply before starting with the replacement.*

High Temperatures – Risk of Burns

Lamps soon become very hot; make sure that the lamps and the lamp compartment have cooled to room temperature before you touch them.

UV Radiation

*The lamps emit intense UV radiation, which can damage your eyes.
Do not open the lamp compartment when the lamps are on.
Do not look directly into a lighted lamp.*

The source lamps are located in the lamp compartment at the top left and rear of the spectrometer, as shown in Figure 31.

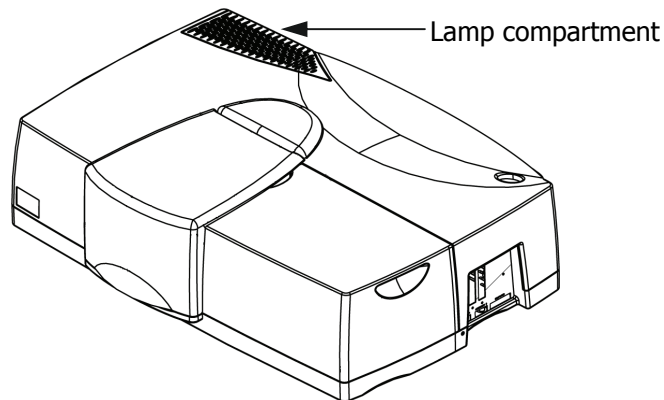

Figure 31 Lamp compartment

Halogen Lamp Replacement

If the lamp burns out, or if the bulb becomes blackened after prolonged use, you should replace the lamp. Replacement lamp assemblies (B0114620) are provided complete with pre-aligned mounts.

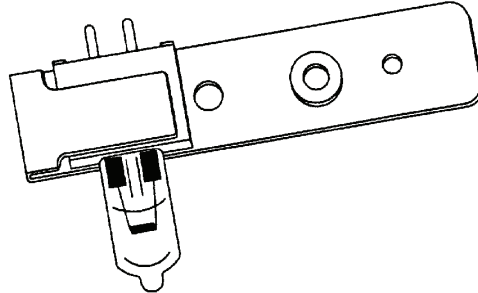

Figure 32 Pre-aligned halogen lamp

To replace the halogen lamp:

1. Switch off the spectrometer and disconnect the line power cord.
If necessary, wait until the lamps and lamp compartment have cooled to room temperature.
2. Remove the lamp compartment cover by lifting vertically from the handhold on the rear of the instrument, as shown in Figure 33.

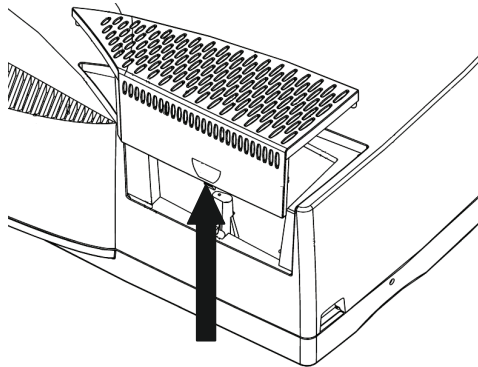

Figure 33 Removing the lamp cover

3. Remove the lamp cover by undoing the two screws and lifting vertically.
4. Carefully pull the halogen lamp connector from the rear of the halogen lamp, as shown in Figure 34.

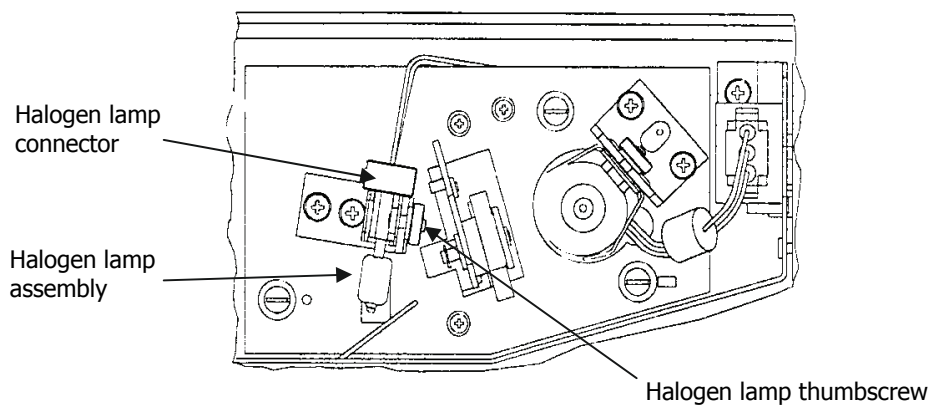

Figure 34 Removing the halogen lamp connector

5. Remove the halogen lamp assembly from the bracket by slackening the thumbscrew and pulling the lamp mount vertically upward.
Save the thumbscrew for use with the new lamp assembly.
6. Unpack the new lamp assembly, taking care to hold it by the metal mount only to prevent finger marks on the bulb.
Finger marks on the lamp window can cause hot spots during operation, which can lead to premature lamp failure.
7. Slip the slot at the base of the lamp mount over the stud on the bracket in the lamp compartment and then secure with the thumbscrew.
8. Carefully push the halogen lamp connector firmly onto the pins on the base of the halogen lamp.
9. Wipe the halogen lamp bulb with a soft cloth moistened with alcohol to remove dirt, since this would otherwise be burned in when the lamp is hot.
10. Replace the lamp compartment cover by lowering it into position.
This completes the halogen lamp replacement procedure.

NOTE: The mounts are pre-aligned, so usually further alignment is not required after installation.

Deuterium Lamp Replacement

If the lamp burns out, or indicates falling energy after prolonged use, you should replace the lamp. Replacement lamp assemblies (B0160917) are provided complete with pre-aligned mounts.



Figure 35 Pre-aligned deuterium lamp assembly (B0160917)

To replace the deuterium lamp:

1. Switch off the spectrometer and disconnect the line power cord.
If necessary, wait until the lamps and lamp compartment have cooled to room temperature.
2. Remove the lamp compartment cover by lifting vertically from the handhold on the rear of the instrument.
3. Remove the lamp cover by undoing the two screws and lifting vertically.
4. Unplug the deuterium lamp connector by squeezing in the two lugs at each side of the connector and carefully pulling the connector vertically upward.

Deuterium lamp assembly

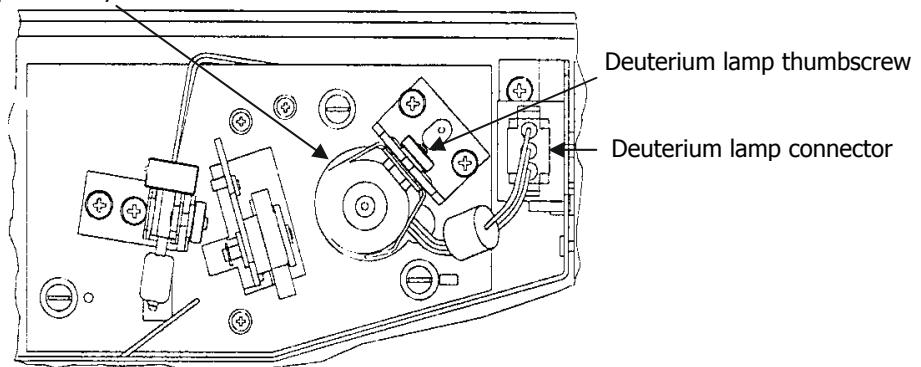

Figure 36 Removing the deuterium lamp connector

5. Remove the lamp assembly from the bracket by slackening the thumbscrew and pulling the lamp mount vertically upward.
Save the thumbscrew for use with the new lamp assembly.
6. Unpack the new lamp assembly, taking care to hold it by the metal mount only to prevent finger marks on the lamp window.
7. Slip the slot at the base of the lamp mount over the stud on the bracket in the lamp compartment and then secure with the thumbscrew.
8. Plug the deuterium lamp connector into the socket.

NOTE: The socket in the lamp compartment is asymmetric; the deuterium lamp connector can be inserted in one orientation only. Make certain that the connector is the right way round before inserting it. Never attempt to insert the connector by force.

9. Wipe the lamp window with a soft cloth moistened with alcohol to remove dirt, since this would otherwise be burned in when the lamp is hot.
10. Replace the lamp compartment cover by lowering into place.
This completes the deuterium lamp replacement procedure.

NOTE: The mounts are pre-aligned, so usually further alignment is not required after installation.

Replacement Parts

Supplies, accessories, and replacement parts can be ordered directly from PerkinElmer. See the PerkinElmer website at <http://www.perkinelmer.com> for more information.

Quantity	Item	Part Number
1	Pack of 10 fuses 3.15 A time delay	B0155573
1	RS 232 printer cable	B0166569
1	Deuterium lamp, pre-aligned	B0160917
1	Halogen lamp, pre-aligned	B0114620
1	Thumbscrew for lamp mount	B0119371
1	Set of sample-compartment windows for Lambda 750, 950 or 1050	B0505982
1	Set of sample-compartment windows for Lambda 650 or 850	L6020417
1	Single-cell holder	B0505071



Appendices

Appendix 1: WEEE Instructions for PerkinElmer Products

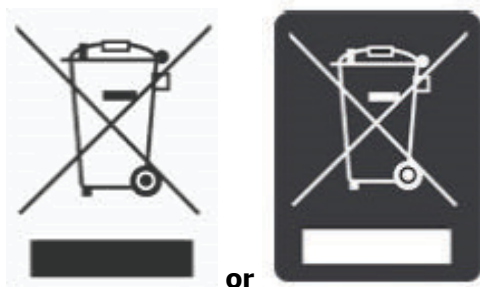

A label with a crossed-out wheeled bin symbol and a rectangular bar indicates that the product is covered by the Waste Electrical and Electronic Equipment (WEEE) Directive and is not to be disposed of as unsorted municipal waste. Any products marked with this symbol must be collected separately, and in accordance with the regulatory guidelines in your area.

The objectives of this program are to preserve, protect and improve the quality of the environment, protect human health, and utilize natural resources prudently and rationally. Specific treatment of WEEE is indispensable in order to avoid the dispersion of pollutants into the recycled material or waste stream. Such treatment is the most effective means of protecting the customer's environment.

The requirements for waste collection, reuse, recycling, and recovery programs are set by the regulatory authority in your location. Contact your local responsible person (such as your laboratory manager) or authorized representative for information regarding applicable disposal regulations.

See the PerkinElmer web address below for information specific to PerkinElmer products, and contact details for the Customer Care department in your region.

<http://las.perkinelmer.com/OneSource/Environmental-directives.htm>

Products from other manufacturers may also form a part of your PerkinElmer system. These other manufacturers are directly responsible for the collection and processing of their own waste products under the terms of the WEEE Directive. Please contact these manufacturers directly before discarding any of their products. Consult the PerkinElmer web address (above) for manufacturer's names and web sites.

Appendix 2: Guaranteed Performance Specifications

Guaranteed Specifications of the UV/Vis Lambda Spectrometers

Specification	Lambda 850	Lambda 650
Principle	Double- beam, double-monochromator, ratio-recording UV/Vis spectrophotometer with microcomputer electronics, controlled by DELL™ PC or compatible personal computer.	
Optical System	All reflecting optical system (SiO ₂ coated) with holographic grating monochromator with 1440 Lines/mm UV/Vis blazed at 240 nm, Littrow mounting, sample-thickness-compensated detector optics.	
Beam Splitting System	Chopper (46+ Hz, Cycle: Dark/Sample/Dark/ Reference, Chopper Segment Signal Correction, CSSC).	
Detector	Photomultiplier R6872 for high energy in the entire UV/Vis wavelength range.	Photomultiplier R955 for high energy in the entire UV/Vis wavelength range.
Source	Pre-aligned tungsten-halogen and deuterium.	Pre-aligned tungsten-halogen and deuterium.
Wavelength Range (N ₂ purge required below 185 nm)	175–900 nm	190–900 nm
UV/Vis Resolution	≤0.05 nm	≤0.17 nm
Stray Light		
At 200 nm (12 g/l KCl USP/DAP method)	>2 A	>2 A
At 220 nm (10 g/l NaI ASTM method)	≤0.00007 %T	≤0.00010 %T
At 340 nm (50 mg/l NaNO ₂ ASTM method)	≤0.00007 %T	≤0.00010 %T
At 370 nm 50 mg/l NaNO ₂ ASTM method)	≤0.00007 %T	≤0.00010 %T
Wavelength Accuracy	±0.080 nm	±0.150 nm
Wavelength Reproducibility		
UV/Vis (Deuterium Lamp Lines)	≤0.020 nm	≤0.060 nm
Standard deviation of 10 UV/Vis measurements	≤0.005 nm	N/A
Photometric Accuracy		
Double aperture method 1 A	±0.0006 A	±0.0012 A
Double aperture method 0.5 A	±0.0003 A	±0.0006 A
NIST 1930D Filters 2 A	±0.0030 A	±0.0030 A
NIST 930D Filters 1 A	±0.0030 A	±0.0030 A
NIST 930D Filters 0.5 A	±0.0020 A	±0.0020 A
K ₂ Cr ₂ O ₇ Solution USP/DAP method	±0.0100 A	±0.0100 A

78 . High-Performance Lambda Spectrometers Hardware Guide

Specification	Lambda 850	Lambda 650
Photometric Linearity (Addition of filters UV/Vis at 546.1 nm, 2 nm slit, 1 second integration time)		
1.0 A	±0.006 A	N/A
2.0 A	±0.017 A	N/A
3.0 A	±0.020 A	±0.020 A
Photometric Reproducibility (Standard deviation for 10 measurements, NIST 930D Filter at 546.1 nm, 2 nm slit, 1 second integration time)		
1.0 A	≤0.00016 A	≤0.00080 A
0.5 A	≤0.00008 A	N/A
0.3 A	≤0.00008 A	≤0.00040 A
Photometric Range	8 A	6 A
Photometric Display	Unlimited	Unlimited
Bandpass	0.05–5.00 nm in 0.01 nm increments. Fixed resolution, constant energy or slit programming.	0.17–5.00 nm in 0.01 nm increments. Fixed resolution, constant energy or slit programming.
Baseline Flatness	±0.0008 A (190–860 nm, 2 nm slit, 0.20 second integration time, no smoothing applied.)	±0.0015 A (200–850 nm, 2 nm slit, 0.20 second integration time, best-fit line.)
Photometric Stability (After warm-up at 500 nm, 0 A, 2 nm slit, 2 second integration time, peak to peak)	≤0.0002 A/h	≤0.0003 A/h
Photometric Noise RMS (2 nm slit, 1 second integration time)		
0 A and 190 nm	≤0.00010 A	≤0.00010 A
0 A and 500 nm	≤0.00005 A	≤0.00005 A
2 A and 500 nm	≤0.00020 A	≤0.00020 A
4 A and 500 nm	≤0.00100 A	≤0.00200 A
6 A and 500 nm	≤0.00500 A	N/A
Sample Compartment Instrument (<i>W</i> × <i>D</i> × <i>H</i>)	200 mm × 300 mm × 220 mm	200 mm × 300 mm × 220 mm
Purging		
Optics	YES	NO
Sample Compartment	YES	NO
Instrument Dimensions (<i>W</i> × <i>D</i> × <i>H</i>)	1020 mm × 740 mm × 300 mm	1020 mm × 740 mm × 300 mm
Instrument Weight	77 kg	77 kg
Digital I/O	RS 232 C	RS 232 C
Light Beam	90 mm above the base plate 120 mm beam separation 3–12 mm beam height	90 mm above the base plate 120 mm beam separation 3–12 mm beam height

Specification	Lambda 850	Lambda 650
Instrument Requirements		
Power	90–250 VAC, 50/60 Hz; 250 VA	90–250 VAC, 50/60 Hz; 250 VA
Temperature	10–35 °C	10–35 °C
Recommended Humidity	10%–70% relative humidity, non-condensing.	10%–70% relative humidity, non-condensing.

Guaranteed Specifications of the UV/Vis/NIR Lambda Spectrometers

Specification	Lambda 1050 NB	Lambda 1050 WB	Lambda 950	Lambda 750
Principle	Double-beam, double-monochromator, ratio- recording UV/Vis/NIR spectrophotometer with microcomputer electronics, controlled by DELL™ PC or compatible personal computer.			
Optical System	All reflecting optical system (SiO ₂ coated) with holographic grating monochromator with 1440 Lines/mm UV/Vis blazed at 240 nm and 360 Lines/mm NIR blazed at 1100 nm, Littrow mounting, sample-thickness-compensated detector optics.			
Beam Splitting System	Chopper (46+ Hz, Cycle: Dark/Sample/Dark/Reference, Chopper Segment Signal Correction, CSSC).			
Detectors	<p>Photomultiplier R6872 for high energy in the entire UV/Vis wavelength range.</p> <p>Combination of high-performance, Peltier-cooled, Narrowband InGaAs detector covering 860–1800 nm and a high-performance Peltier-cooled PbS detector covering 1800–3300 nm, in the NIR wavelength range.</p>	<p>Photomultiplier R6872 for high energy in the entire UV/Vis wavelength range.</p> <p>Combination of high-performance, Peltier-cooled, Wideband InGaAs detector covering 860–2500 nm and a high-performance Peltier-cooled PbS detector covering 1800–3300 nm, in the NIR wavelength range.</p>	<p>Photomultiplier R6872 for high energy in the entire UV/Vis wavelength range.</p> <p>Peltier cooled PbS detector for the entire NIR wavelength range.</p>	<p>Photomultiplier R955 for high energy in the entire UV/Vis wavelength range.</p> <p>Peltier cooled PbS detector for the entire NIR wavelength range.</p>
Source	<p>Pre-aligned tungsten-halogen and deuterium.</p> <p>Utilizes a source-doubling mirror for improved UV/Vis/NIR energy.</p>	<p>Pre-aligned tungsten-halogen and deuterium.</p> <p>Utilizes a source-doubling mirror for improved UV/Vis/NIR energy.</p>	<p>Pre-aligned tungsten-halogen and deuterium.</p>	<p>Pre-aligned tungsten-halogen and deuterium.</p>
Wavelength Range (N ₂ purge required below 185 nm)	175–3300 nm	175–3300 nm	175–3300 nm	190–3300 nm
UV/Vis Resolution	≤0.05 nm	≤0.05 nm	≤0.05 nm	≤0.17 nm
NIR Resolution	≤0.20 nm	≤0.20 nm	≤0.20 nm	≤0.20 nm

80 . High-Performance Lambda Spectrometers Hardware Guide

Specification	Lambda 1050 NB	Lambda 1050 WB	Lambda 950	Lambda 750
Stray Light				
At 200 nm (12 g/l KCl USP/DAP method)	>2 A	>2 A	>2 A	>2 A
At 220 nm (10 g/l NaI ASTM method)	≤0.00007 %T	≤0.00007 %T	≤0.00007 %T	≤0.00010 %T
At 340 nm (50 mg/l NaNO ₂ ASTM method)	≤0.00007 %T	≤0.00007 %T	≤0.00007 %T	≤0.00010 %T
At 370 nm 50 mg/l NaNO ₂ ASTM method)	≤0.00007 %T	≤0.00007 %T	≤0.00007 %T	≤0.00010 %T
At 1420 nm (H ₂ O 1 cm pathlength)	≤0.00040 %T	≤0.00040 %T	≤0.00040 %T	≤0.00040 %T
At 2365 nm (CHCl ₃ , 1 cm pathlength)	≤0.00050 %T	≤0.00050 %T	≤0.00050 %T	≤0.00100 %T
Wavelength Accuracy	±0.080 nm UV/Vis ±0.300 nm NIR	±0.080 nm UV/Vis ±0.300 nm NIR	±0.080 nm UV/Vis ±0.300 nm NIR	±0.150 nm UV/Vis ±0.500 nm NIR
Wavelength Reproducibility				
UV/Vis (Deuterium Lamp Lines)	≤0.010 nm	≤0.010 nm	≤0.020 nm	≤0.060 nm
NIR (Deuterium Lamp Lines)	≤0.040 nm	≤0.040 nm	≤0.080 nm	≤0.100 nm
Standard deviation of 10 UV/Vis measurements	≤0.005 nm	≤0.005 nm	≤0.005 nm	N/A
Standard deviation of 10 NIR measurements	≤0.020 nm	≤0.020 nm	≤0.020 nm	N/A
Photometric Accuracy				
Double Aperture method 1 A	±0.0003 A	±0.0003 A	±0.0006 A	±0.0012 A
Double Aperture method 0.5 A	±0.0003 A	±0.0003 A	±0.0003 A	N/A
NIST 1930D Filters 2 A	±0.0030 A	±0.0030 A	±0.0030 A	±0.0030 A
NIST 930D Filters 1 A	±0.0030 A	±0.0030 A	±0.0030 A	±0.0030 A
NIST 930D Filters 0.5 A	±0.0020 A	±0.0020 A	±0.0020 A	±0.0020 A
K ₂ Cr ₂ O ₇ Solution USP/DAP method	±0.0080 A	±0.0080 A	±0.0100 A	±0.0100 A

Specification	Lambda 1050 NB	Lambda 1050 WB	Lambda 950	Lambda 750
<p>Photometric Linearity (Addition of filters UV/Vis at 546.1 nm, 2 nm slit, 1 second integration time)</p> <p>1.0 A</p> <p>2.0 A</p> <p>3.0 A</p> <p>NIR 1.0 A (1200 nm)</p> <p>NIR 2.0 A (1200 nm)</p>	<p>±0.0060 A</p> <p>±0.0160 A</p> <p>±0.0050 A</p> <p>±0.0005 A</p> <p>±0.0010 A</p>	<p>±0.0060 A</p> <p>±0.0160 A</p> <p>±0.0050 A</p> <p>±0.0005 A</p> <p>±0.0010 A</p>	<p>±0.0060 A</p> <p>±0.0170 A</p> <p>±0.0200 A</p> <p>N/A</p> <p>N/A</p>	<p>N/A</p> <p>N/A</p> <p>±0.0200 A</p> <p>N/A</p> <p>N/A</p>
<p>Photometric Reproducibility (Standard deviation for 10 measurements, 2 nm slit, 1 second integration time)</p> <p>1.0 A with NIST 930D Filter at 546.1 nm</p> <p>0.5 A with NIST 930D Filter at 546.1 nm</p> <p>0.3 A with NIST 930D Filter at 546.1 nm</p>	<p>≤0.00016 A</p> <p>≤0.00008 A</p> <p>≤0.00008 A</p>	<p>≤0.00016 A</p> <p>≤0.00008 A</p> <p>≤0.00008 A</p>	<p>≤0.00016 A</p> <p>≤0.00008 A</p> <p>≤0.00008 A</p>	<p>≤0.0008 A</p> <p>N/A</p> <p>≤0.0004 A</p>
<p>Photometric Range</p> <p>UV/Vis</p> <p>NIR</p>	<p>8 A</p> <p>8 A</p>	<p>8 A</p> <p>8 A</p>	<p>8 A</p> <p>6 A</p>	<p>6 A</p> <p>6 A</p>
Photometric Display	Unlimited	Unlimited	Unlimited	Unlimited
<p>Bandpass</p> <p>0.05–5.00 nm in 0.01 nm increments UV/Vis range</p> <p>0.20–20.00 nm in 0.04 nm increments NIR range.</p> <p>Fixed resolution, constant energy or slit programming.</p>	<p>0.05–5.00 nm in 0.01 nm increments UV/Vis range</p> <p>0.20–20.00 nm in 0.04 nm increments NIR range.</p> <p>Fixed resolution, constant energy or slit programming.</p>	<p>0.05–5.00 nm in 0.01 nm increments UV/Vis range</p> <p>0.20–20.00 nm in 0.04 nm increments NIR range.</p> <p>Fixed resolution, constant energy or slit programming.</p>	<p>0.05–5.00 nm in 0.01 nm increments UV/Vis range</p> <p>0.20–20.00 nm in 0.04 nm increments NIR range.</p> <p>Fixed resolution, constant energy or slit programming.</p>	<p>0.17–5.00 nm in 0.10 nm increments UV/Vis range</p> <p>0.20–20.00 nm in 0.40 nm increments NIR range.</p> <p>Fixed resolution, constant energy or slit programming.</p>
Photometric Stability (After warm-up at 500 nm, 0 A, 2 nm slit, 2 second integration time, peak to peak)	≤0.0002 A/h	≤0.0002 A/h	≤0.0002 A/h	≤0.0002 A/h

82 . High-Performance Lambda Spectrometers Hardware Guide

Specification	Lambda 1050 NB	Lambda 1050 WB	Lambda 950	Lambda 750
Baseline Flatness (190–3100 nm, 2 nm slit, 0.20 second UV/Vis integration time, no smoothing applied, 0.24 second NIR integration time, no smoothing applied.)	±0.0008 A	±0.0008 A	±0.0008 A	±0.0015 A
Photometric Noise RMS (2 nm slit, 1 second integration time)				
0 A and 190 nm	≤0.00010 A	≤0.00010 A	≤0.00010 A	≤0.00010 A
0 A and 500 nm	≤0.00005 A	≤0.00005 A	≤0.00005 A	≤0.00005 A
2 A and 500 nm	≤0.00020 A	≤0.00020 A	≤0.00020 A	≤0.00020 A
4 A and 500 nm	≤0.00100 A	≤0.00100 A	≤0.00100 A	≤0.00020 A
6 A and 500 nm	≤0.00500 A	≤0.00500 A	≤0.00500 A	N/A
0 A and 1500 nm	≤0.00002 A	≤0.00002 A	≤0.00004 A	≤0.00004 A
2 A and 1500 nm	≤0.00010 A	≤0.00010 A	≤0.00010 A	N/A
3 A and 1500 nm (PbS, servo mode)	≤0.00250 A	≤0.00250 A	≤0.00300 A	≤0.00300 A
0 A and 1500 nm (InGaAs)	≤0.00002 A	≤0.00002 A	N/A	N/A
2 A and 1500 nm (InGaAs)	≤0.00010 A	≤0.00010 A	N/A	N/A
3 A and 1500 nm (InGaAs, servo mode)	≤0.000025 A	≤0.00010 A	N/A	N/A
Sample Compartment Instrument (<i>W</i> × <i>D</i> × <i>H</i>)	200 mm × 300 mm × 220 mm	200 mm × 300 mm × 220 mm	200 mm × 300 mm × 220 mm	200 mm × 300 mm × 220 mm
Purging				
Optics	YES	YES	YES	NO
Sample Compartment	YES	YES	YES	NO
Instrument Dimensions (<i>W</i> × <i>D</i> × <i>H</i>)	1020 mm × 740 mm × 300 mm	1020 mm × 740 mm × 300 mm	1020 mm × 740 mm × 300 mm	1020 mm × 740 mm × 300 mm
Instrument Weight	77 kg	77 kg	77 kg	77 kg
Digital I/O	RS 232 C	RS 232 C	RS 232 C	RS 232 C
Light Beam	90 mm above the base plate 120 mm beam separation 3–12 mm beam height	90 mm above the base plate 120 mm beam separation 3–12 mm beam height	90 mm above the base plate 120 mm beam separation 3–12 mm beam height	90 mm above the base plate 120 mm beam separation 3–12 mm beam height

Specification	Lambda 1050 NB	Lambda 1050 WB	Lambda 950	Lambda 750
Instrument Requirements				
Power	90 VAC–250 VAC, 50/60 Hz; 250 VA	90 VAC–250 VAC, 50/60 Hz; 250 VA	90 VAC–250 VAC, 50/60 Hz; 250 VA	90 VAC–250 VAC, 50/60 Hz; 250 VA
Temperature	10–35 °C	10–35 °C	10–35 °C	10–35 °C
Recommended Humidity	10%–70% relative humidity, non-condensing.	10%–70% relative humidity, non-condensing.	10%–70% relative humidity, non-condensing.	10%–70% relative humidity, non-condensing.

